



# COSAMS Generic

## User Manual

Commercial in Confidence

### UK Office

15 Ellerbeck Court,  
Stokesley Business Park,  
North Yorkshire, TS9 5PT, UK



### US Office

15121 Graham Street #B106,  
Huntington Beach, California,  
92649

### UK / Global

info@analox.biz  
+44 (0)1642 711 400  
+44 (0) 1642 713 900



### US Office



ussales@analox.biz  
(714) 891 4478  
Toll Free: (877) 723 3247  
(714) 891 4479



## Table of Contents

|          |   |           |
|----------|---|-----------|
| <b>1</b> | <b>Introduction</b>                         | <b>8</b>  |
| <b>2</b> | <b>Modification state control</b>           | <b>9</b>  |
| <b>3</b> | <b>System checklist</b>                     | <b>11</b> |
| <b>4</b> | <b>Transport and storage considerations</b> | <b>12</b> |
| <b>5</b> | <b>Installation details</b>                 | <b>13</b> |
| 5.1      | <b>Overview</b>                             | <b>13</b> |
| 5.1.1    | Tools/consumables required for installation | 13        |
| 5.2      | <b>Mechanical installation</b>              | <b>14</b> |
| 5.2.1    | Mounting COSAMS                             | 14        |
| 5.3      | <b>Electrical installation</b>              | <b>16</b> |
| 5.3.1    | AC Cable identification                     | 17        |
| 5.3.2    | DC Cable identification                     | 18        |
| 5.3.3    | Signal output                               | 19        |
| 5.3.4    | Equipotential bonding strap                 | 19        |
| <b>6</b> | <b>Technical description</b>                | <b>20</b> |
| 6.1      | <b>Gas sampling</b>                         | <b>20</b> |
| 6.2      | <b>Power supply</b>                         | <b>23</b> |
| 6.2.1    | Power supply (AC variant)                   | 23        |
| 6.2.2    | Power supply (DC variant)                   | 23        |
| 6.3      | <b>Power distribution</b>                   | <b>23</b> |
| 6.4      | <b>CO sensor</b>                            | <b>23</b> |
| 6.5      | <b>5S3 control interface</b>                | <b>24</b> |
| 6.6      | <b>SDA operator console</b>                 | <b>24</b> |
| 6.7      | <b>SDA output module</b>                    | <b>24</b> |
| 6.8      | <b>Electrical schematic (AC variant)</b>    | <b>25</b> |
| 6.9      | <b>Electrical schematic (DC variant)</b>    | <b>26</b> |
| <b>7</b> | <b>Operating instructions</b>               | <b>28</b> |
| 7.1      | <b>Controls</b>                             | <b>28</b> |
| 7.2      | <b>Start-up</b>                             | <b>28</b> |
| 7.3      | <b>Warm-up</b>                              | <b>29</b> |
| 7.4      | <b>Normal operation</b>                     | <b>29</b> |
| 7.4.1    | System status indicator                     | 29        |
| 7.5      | <b>Menu</b>                                 | <b>30</b> |
| 7.5.1    | Adjusting the backlight                     | 31        |
| 7.5.2    | Auto-zero function                          | 32        |
| 7.5.3    | Replacing catalyst                          | 32        |
| 7.5.4    | Resetting the service interval timer        | 32        |
| 7.5.5    | COSAMS information                          | 32        |
| 7.5.6    | Data logging                                | 33        |
| <b>8</b> | <b>Calibration</b>                          | <b>37</b> |
| 8.1      | <b>Zero and span calibration</b>            | <b>37</b> |
| 8.1.1    | Performing a <i>zero</i> calibration        | 37        |
| 8.1.2    | Performing a <i>span</i> calibration        | 38        |
| <b>9</b> | <b>Alarms</b>                               | <b>39</b> |
| 9.1      | <b>Adjusting alarm set points</b>           | <b>39</b> |
| 9.2      | <b>Acknowledging alarms</b>                 | <b>39</b> |

|                   |   |           |
|-------------------|---|-----------|
| 9.3               | Clearing alarms and hysteresis.....                     | 40        |
| <b>10</b>         | <b>Technical in-service support software .....</b>      | <b>41</b> |
| <b>11</b>         | <b>Troubleshooting.....</b>                             | <b>42</b> |
| 11.1              | Fault announcement.....                                 | 42        |
| 11.2              | Fault diagnosis.....                                    | 42        |
| 11.3              | Fault logging.....                                      | 42        |
| <b>12</b>         | <b>Maintenance .....</b>                                | <b>45</b> |
| 12.1              | Spare parts .....                                       | 45        |
| 12.2              | Special maintenance equipment.....                      | 46        |
| 12.3              | Periodic maintenance.....                               | 47        |
| 12.3.1            | Filter check and replacement.....                       | 50        |
| 12.3.2            | Auto-zero catalyst replacement.....                     | 52        |
| 12.3.3            | Cabinet breather inspection/replacement.....            | 52        |
| 12.3.4            | Removal and replacement of the baseplate assembly ..... | 53        |
| 12.3.5            | Sample pump replacement.....                            | 55        |
| 12.3.6            | Infra-red source replacement.....                       | 57        |
| 12.4              | Non-periodic maintenance.....                           | 60        |
| 12.4.1            | Solenoid valve replacement.....                         | 60        |
| 12.4.2            | Flow switch replacement.....                            | 61        |
| 12.4.3            | Replacing the power supply unit (AC variant).....       | 62        |
| 12.4.4            | Replacing the power supply unit (DC variant).....       | 64        |
| 12.4.5            | Replacing the SDA Output Module PCB.....                | 65        |
| 12.4.6            | Replacing SDA Operator Console membrane label.....      | 66        |
| 12.4.7            | Replacing the SDA Operator Console.....                 | 67        |
| 12.4.8            | CO sensor calibration.....                              | 68        |
| <b>13</b>         | <b>Warranty.....</b>                                    | <b>71</b> |
| <b>14</b>         | <b>Fault reporting to Analox .....</b>                  | <b>72</b> |
| <b>15</b>         | <b>Specifications.....</b>                              | <b>73</b> |
| 15.1              | Mechanical specifications .....                         | 73        |
| 15.2              | Electrical specifications (AC variant) .....            | 73        |
| 15.3              | Electrical specifications (DC variant).....             | 73        |
| 15.4              | Environmental specifications .....                      | 74        |
| 15.5              | Performance specifications .....                        | 74        |
| <b>16</b>         | <b>Disposal.....</b>                                    | <b>75</b> |
| 16.1              | WEEE statement.....                                     | 75        |
| 16.2              | Catalyst disposal.....                                  | 75        |
| <b>Appendix A</b> | <b>PremiOx Gold safety datasheet.....</b>               | <b>76</b> |
| <b>Appendix B</b> | <b>Nanaucat safety data sheet .....</b>                 | <b>81</b> |

## List of figures



|           |   |    |
|-----------|---|----|
| Figure 1  | Modification state label .....                            | 9  |
| Figure 2  | Baseplate modification state label .....                  | 10 |
| Figure 3  | COSAMS overview .....                                     | 13 |
| Figure 4  | Mounting arrangement.....                                 | 14 |
| Figure 5  | Relative positions of COSAMS mounting holes .....         | 15 |
| Figure 6  | COSAMS internal pneumatic arrangement.....                | 20 |
| Figure 7  | COSAMS internal electrical arrangement (AC variant) ..... | 21 |
| Figure 8  | COSAMS internal electrical arrangement (DC variant))..... | 22 |
| Figure 9  | Internal wiring schematic (AC variant) .....              | 25 |
| Figure 10 | Internal Wiring Schematic (Cabinet) (DC variant) .....    | 26 |
| Figure 11 | Internal Wiring Schematic (Baseplate) (DC variant) .....  | 27 |
| Figure 12 | COSAMS front panel.....                                   | 28 |
| Figure 13 | Start-up splash screen.....                               | 28 |
| Figure 14 | Warm-up screen.....                                       | 29 |
| Figure 15 | Main display overview .....                               | 29 |
| Figure 16 | The main menu.....  | 30 |
| Figure 17 | The backlight sub-menu .....                              | 31 |
| Figure 18 | Zeroing sensor indication .....                           | 32 |
| Figure 19 | COSAMS information screen.....                            | 32 |
| Figure 20 | Example of data logged by system .....                    | 33 |
| Figure 21 | Span adjustment .....                                     | 38 |
| Figure 22 | Example of alarm set-point adjustment.....                | 39 |
| Figure 23 | Alarm hysteresis .....                                    | 40 |
| Figure 24 | Fault indication (example of a flow fault) .....          | 42 |
| Figure 25 | COSAMS internal components (1).....                       | 48 |
| Figure 26 | COSAMS internal components (2).....                       | 49 |

## List of tables

|          |                                       |    |
|----------|---------------------------------------|----|
| Table 1  | Cabinet modification state.....       | 9  |
| Table 2  | Baseplate modification state .....    | 10 |
| Table 3  | System checklist.....                 | 11 |
| Table 4  | Connector details.....                | 17 |
| Table 5  | Connector pin-out .....               | 17 |
| Table 6  | Connector details.....                | 18 |
| Table 7  | Connector pin-out .....               | 18 |
| Table 8  | SDA operator console menu items ..... | 30 |
| Table 9  | Fault codes.....                      | 44 |
| Table 10 | COSAMS spare parts list.....          | 46 |
| Table 11 | Special maintenance equipment.....    | 46 |
| Table 12 | On board maintenance tasks .....      | 47 |

## **Warnings, cautions and notes**

Warnings and Cautions are used in this Manual to highlight potential hazards and safety risks. Notes are used to provide supplementary information that is not hazard-related.

-  **WARNING:** THIS INDICATES A POTENTIALLY HAZARDOUS SITUATION THAT, IF NOT AVOIDED, COULD RESULT IN DEATH OR SERIOUS INJURY.
-  **CAUTION:** THIS INDICATES A POTENTIALLY HAZARDOUS SITUATION THAT, IF NOT AVOIDED, COULD RESULT IN EQUIPMENT DAMAGE OR LOSS OF DATA.
-  **NOTE:** THIS INDICATES INFORMATION THAT IS CONSIDERED IMPORTANT BUT IS NOT HAZARD RELATED.

## **Safety information**

Please read this manual prior to installing and using the Analox COSAMS, paying particular attention to the following safety information:

- ⚠ WARNING: DISCONNECT THE POWER SUPPLY BEFORE PERFORMING ANY MAINTENANCE WITHIN THE CABINET.**
  
- ⚠ WARNING: HIGH PRESSURE GAS SUPPLY MUST NOT BE APPLIED TO EITHER OF THE COSAMS GAS PORTS. TO DO SO MAY RESULT IN DAMAGE TO THE COSAMS SYSTEM AND THE POSSIBLE EMISSION OF PROJECTILES. GAS PRESSURE AT THE INLET PORT MUST NOT EXCEED 500HPA (GAUGE PRESSURE). DO NOT OBSTRUCT THE EXHAUST PORT.**
  
- ⚠ WARNING: THE COSAMS CONTAINS A SMALL QUANTITY OF CATALYST WHICH MUST BE REPLACED DURING ROUTINE SERVICING. THIS MATERIAL MAY CAUSE IRRITATION OF THE EYES, NOSE, THROAT AND SKIN BUT UNDER NORMAL CIRCUMSTANCES AN OPERATOR/TECHNICIAN WILL NOT COME INTO CONTACT WITH THIS MATERIAL. MATERIAL SAFETY DATASHEETS (MSDS) ARE INCLUDED IN THE APPENDICES.**
  
- ⚠ WARNING: SOME COMPONENTS OF THE GFC CO SENSOR, MOUNTED WITHIN THE COSAMS CABINET, ARE CONTROLLED TO 50°C DURING NORMAL OPERATION OF THE SENSOR. THE SENSOR SHOULD BE ALLOWED TO COOL A LITTLE BEFORE HANDLING.**

## **1 Introduction**

This manual details installation, operation and maintenance of the Analox COSAMS carbon monoxide (CO) sensor, developed for the submarine atmosphere monitoring system.

Each COSAMS indicates the local CO concentration on a colour LCD and transmits a corresponding 4-20mA signal to the submarine's Central Air Monitoring System.

The COSAMS user interface permits calibration of the sensor and may be used to provide a local visual alarm, if desired.



## 2 Modification state control

Each instrument is fitted with a serial number plate, as shown below:

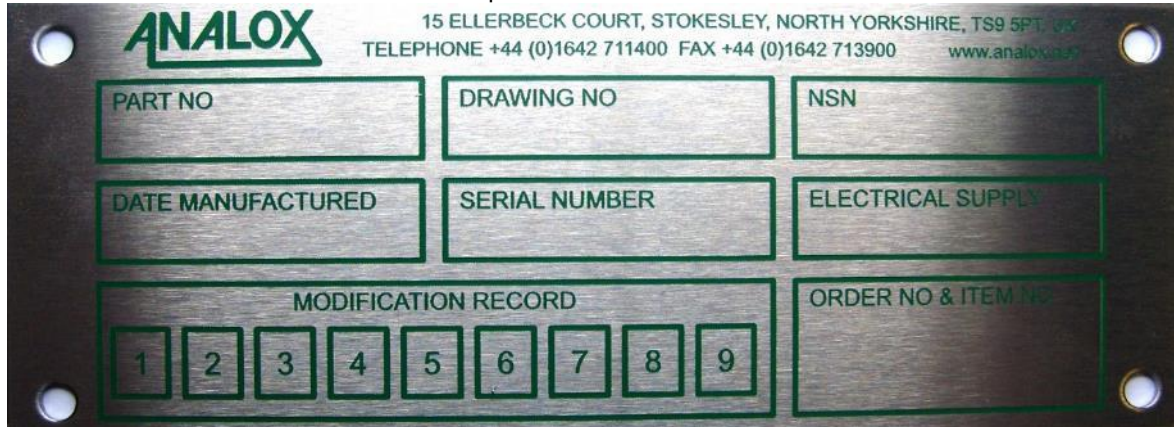

**Figure 1 Modification state label**

The first COSAMS delivered will initially have no modification numbers crossed out, this is interpreted as "Modification State 0".

As design changes are made that affect the form or function of the instrument, the *Modification Record* boxes will be used to track changes made to individual units. For example, as an instrument receives the first authorised modification it will have the '1' box crossed out, signifying that it is now at modification state 1. Design changes that are applied to ALL delivered instruments in a controlled and timely manner may be done without updating the modification record; the purpose of the modification record is to signify the differences between instruments.

| Modification state | Date authorised | Details                |
|--------------------|-----------------|------------------------|
| 0                  |                 | First article delivery |
| 1                  |                 |                        |
| 2                  |                 |                        |
| 3                  |                 |                        |
| 4                  |                 |                        |
| 5                  |                 |                        |
| 6                  |                 |                        |
| 7                  |                 |                        |
| 8                  |                 |                        |
| 9                  |                 |                        |

**Table 1 Cabinet modification state**

The baseplate is fitted with a modification state label as shown below:

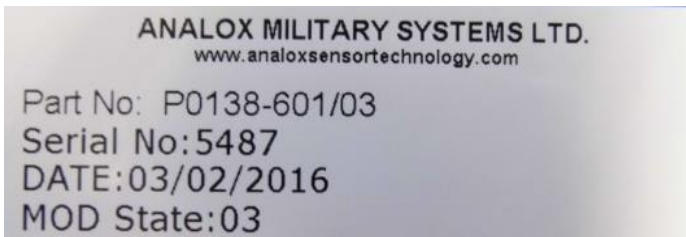

**Figure 2 Baseplate modification state label**

As design changes are made that affect the form or function of the instrument, the *Modification Record* boxes will be used to track changes made to individual units. For example, as an instrument receives the first authorised modification it will have state '01' after MOD State, signifying that it is now at modification state 1. Design changes that are applied to ALL delivered instruments in a controlled and timely manner may be done without updating the modification record; the purpose of the modification record is to signify the differences between instruments.

| Modification state | Date authorised/DCN No | Details                |
|--------------------|------------------------|------------------------|
| 0                  |                        | First article delivery |
| 1                  |                        |                        |
| 2                  |                        |                        |
| 3                  |                        |                        |

**Table 2 Baseplate modification state**

### **3 System checklist**





Each system, suitable for fitting out one submarine, comprises the following items:

| <b>Item</b> | <b>Description</b>                       |
|-------------|--|
| 1.          | COSAMS instrument                        |
| 2.          | Power input connector                    |
| 3.          | Signal output connector                  |
| 4.          | Enclosure locking key                    |
| 5.          | 2m length of calibration sample tube     |
| 6.          | USB lead                                 |
| 7.          | COSAMS software CD                       |
| 8.          | User Manual                              |
| 9.          | Test Certificate/statement of Conformity |

**Table 3 System checklist**

## **4 Transport and storage considerations**

To avoid equipment damage when storing or transporting a COSAMS unit it must always be packed in suitable transport packaging.

-  **CAUTION:** WHEN STORING OR TRANSPORTING A COSAMS UNIT IT MUST ALWAYS BE PACKED IN SUITABLE TRANSPORT PACKAGING.
-  **CAUTION:** PRIOR TO POWERING UP THE INSTRUMENT, IT SHOULD ALWAYS BE ALLOWED TO RETURN TO ITS OPERATING TEMPERATURE RANGE AND ANY CONDENSATE THAT MAY HAVE FORMED MUST BE ALLOWED TO EVAPORATE.
-  **NOTE:** DETAILS OF PERMISSIBLE STORAGE TEMPERATURE, HUMIDITY AND PRESSURE RANGES CAN BE FOUND IN SECTION 15, ENVIRONMENTAL SPECIFICATIONS.
-  **NOTE:** THE COSAMS WILL REQUIRE CALIBRATION AFTER TRANSPORT OR STORAGE.

## **5 Installation details**

### **5.1 Overview**

The COSAMS electronics are housed in a custom-made cabinet fabricated from 5000 series aluminium. External surfaces are painted with RAL7001 (silver grey) epoxy paint to DTD5555A (MIL-22750F) with low-profile spatter finish.

The cabinet has two lugs per side for direct-mounting to a bulkhead.

The enclosure achieves a minimum ingress protection of IP44.

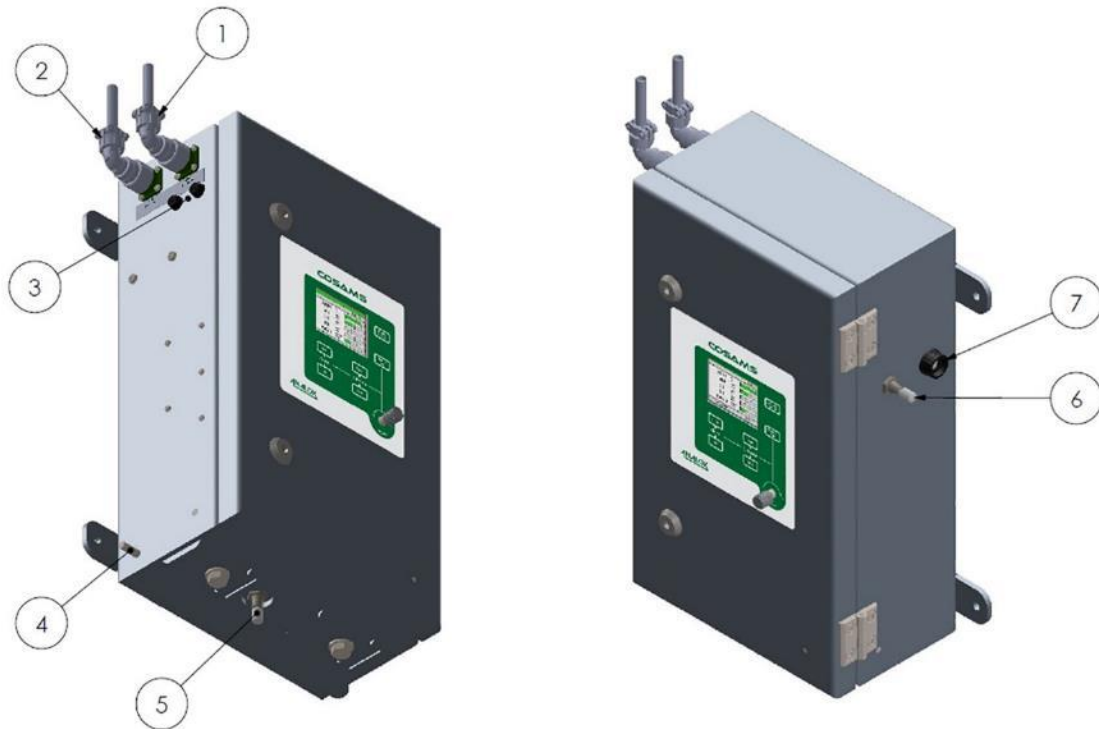

**Figure 3 COSAMS overview**

Access is required from the left hand side for the electrical connections:

- power input (1)
- 4-20mA signal output (2)
- earth stud for equipotential bonding to the submarine hull (4)

Two waterproof fuse holders are also accessed from the left hand side (3) (DC variant).

The fuse holders are located internally for the AC variant.

Gas sample is drawn through an inlet (5) in the cabinet's base and exhausts out of the right hand side (6). A water-proof breather port (7) is also mounted on the right hand side to ensure that cabinet internal pressure tracks submarine compartment pressure.

Push-fit sinters are supplied with the COSAMS and one should be fitted in both the inlet and exhaust ports to pre-filter the sample and guard against water entry in the event of splashing.

Access to the cabinet base and right-hand side will be required to maintain the pre-filters and also when applying calibration gas to the COSAMS.

#### **5.1.1 Tools/consumables required for installation**

Installation of the hardware is possible using standard hand tools (i.e. spanners/socket set, screwdrivers, hex keys, soldering iron, etc.); no special tools or consumables are required.

Upon installation, the system should be calibrated according to section 8.

## **5.2 Mechanical installation**

### **5.2.1 Mounting COSAMS**



**Figure 4 Mounting arrangement**

M8 hardware should be used to securely bolt the COSAMS using the two mounting lugs protruding from either side; the relative positions of the rectangularly arranged mounting holes (330 x 369mm centres) are indicated in Figure 5

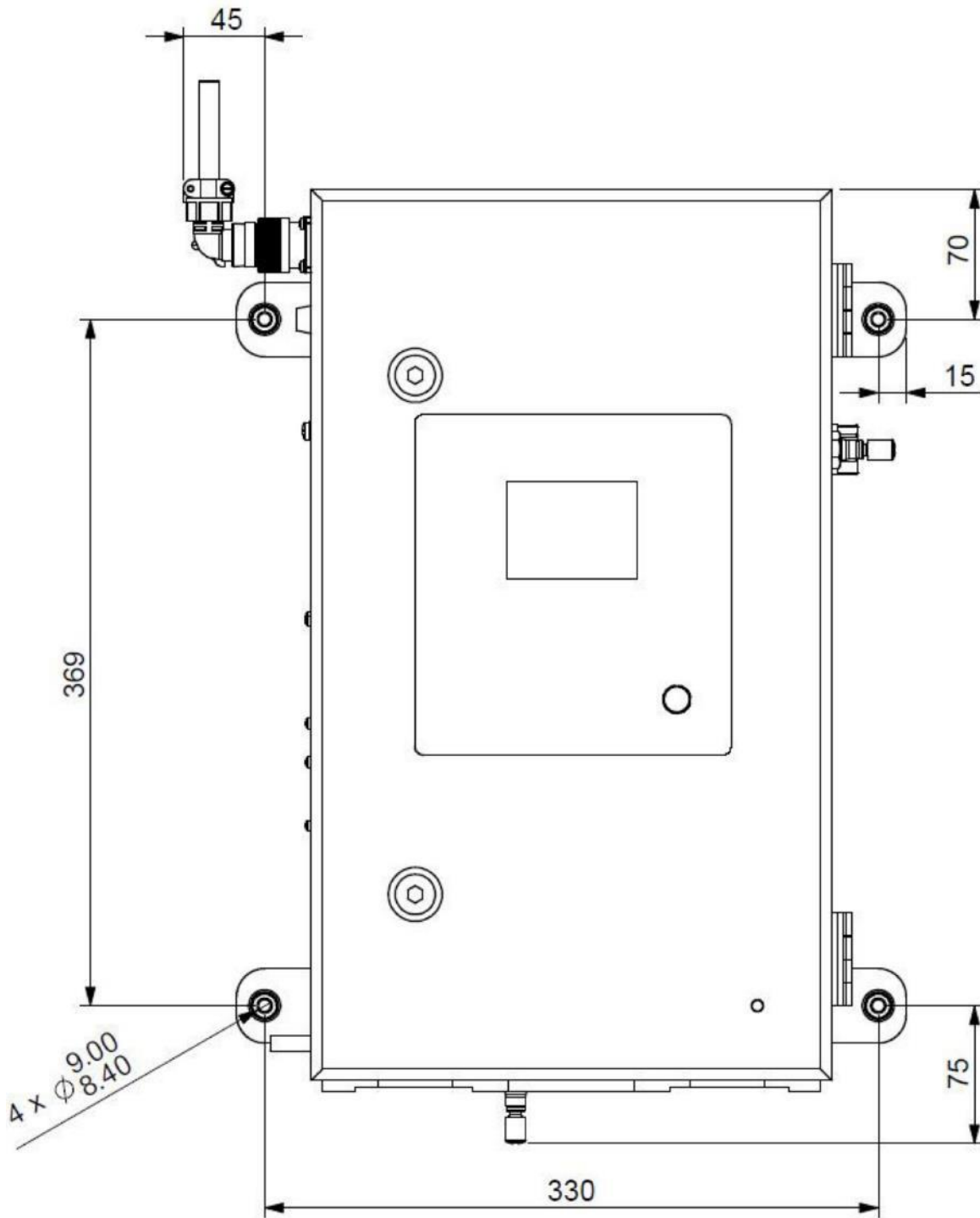

Figure 5 Relative positions of COSAMS mounting holes

### **5.3 Electrical installation**

Three external electrical connections are required to the COSAMS:

- power input
- signal output
- equipotential bonding strap

The COSAMS cabinet has a 3 way male, chassis mounted plug for power connection, 2 power variant options are available, an AC, 85-264Vac, 47 - 63Hz with a maximum power consumption of 90W, and a DC variant, 24Vdc with a maximum power consumption of 150W . A mating connector (3-way, female, cable-mounting socket) is supplied with COSAMS.

 **NOTE: THE DESIRED SUPPLY VOLTAGE IS FACTORY FIT ONLY AND SHOULD BE DECIDED PRIOR TO ORDERING.**

A 3-way, female, chassis-mounted socket provides connection to the 4-20mA output signal and a mating connector (3-way, male, cable-mounting plug) is supplied with COSAMS.



**5.3.1 AC Cable identification**

AC version cables are to be terminated as follows:

|   | Connector description                                | Manufacturer's part number |
|---|--|----------------------------|
| <b>Power input<br/>(85 to 264Vac, 47 to 63Hz)</b> | VG95234/MIL-STD-5015C 3-way cable female socket, 90° | ITT Cannon CB8U14S-7SS     |
| <b>Signal output (4-20mA)</b>                     | VG95234/MIL-STD-5015C 3-way cable male plug, 90°     | ITT Cannon CB8U14S-7PS     |

**Table 4 Connector details**

|   | Pin no.                        | Function      | Cable core          |
|---|--------------------------------|---------------|---------------------|
| <b>Power input<br/>(85 to 264Vac, 47 to 63Hz)</b> | 1                              | L1            | Installer to advise |
|   | 2                              | L2            |                     |
|   | 3 [refer to the CAUTION below] | Earth         | Not connected       |
|   | Body                           | Earth         | Screen              |
| <b>Signal output (4-20mA)</b>                     | 1                              | Signal +      | Installer to advise |
|   | 2                              | Signal -      |                     |
|   | 3                              | Not connected | Not connected       |
|   | Body                           | Earth         | Screen              |

**Table 5 Connector pin-out**

 **CAUTION:** **NO CONNECTION IS TO BE MADE TO PIN 3 OF THE CABLE MOUNTED POWER CONNECTOR. PIN 3 OF THE COSAMS CABINET-MOUNTED PLUG IS CONNECTED TO THE CABINET BODY IN ORDER TO MAKE PROTECTIVE EARTH CONNECTION DURING FACTORY SET UP AND TESTING.**

**5.3.2 DC Cable identification**

DC version cables are to be terminated as follows:

|                               | <b>Connector description</b>                              | <b>Manufacturer's part number</b> |
|-------------------------------|---|-----------------------------------|
| <b>Power input (24Vdc)</b>    | VG95234/MIL-STD-5015C 3-way cable female socket, straight | ITT Cannon CB6U16-10SS            |
| <b>Signal output (4-20mA)</b> | VG95234/MIL-STD-5015C 3-way cable male plug, straight     | ITT Cannon CB6UE14S-7PS           |

**Table 6 Connector details**

|                               | <b>Pin no.</b>                 | <b>Function</b> | <b>Cable core</b>   |
|-------------------------------|--------------------------------|-----------------|---------------------|
| <b>Power input (24Vdc)</b>    | A                              | +VE             | Installer to advise |
|                               | B                              | -VE             |                     |
|                               | C [refer to the CAUTION below] | Earth           | Not connected       |
|                               | Body                           | Earth           | Screen              |
| <b>Signal output (4-20mA)</b> | A                              | Signal +        | Installer to advise |
|                               | B                              | Signal -        |                     |
|                               | C                              | Not connected   | Not connected       |
|                               | Body                           | Earth           | Screen              |

**Table 7 Connector pin-out**

 **CAUTION:** **NO CONNECTION IS TO BE MADE TO PIN 3 OF THE CABLE MOUNTED POWER CONNECTOR. PIN 3 OF THE COSAMS CABINET-MOUNTED PLUG IS CONNECTED TO THE CABINET BODY IN ORDER TO MAKE PROTECTIVE EARTH CONNECTION DURING FACTORY SET UP AND TESTING.**

### **5.3.3 Signal output**

An Analox SDA output module controls a 4-20mA analogue signal proportional to the perceived CO concentration over the range 0-200ppm. The module is configured to operate in active mode and compliance is maintained for loop resistances up to 500Ω.

The analogue output is set to ~2mA during warm-up and in the case of a fault condition being detected.

During the course of an auto-zero operation the 4-20mA output is maintained at a value corresponding to the CO measurement recorded immediately prior to initiating the auto-zero.

### **5.3.4 Equipotential bonding strap**

A suitable flexible bonding strap must be attached to the COSAMS M8 earth bonding stud. This will be the means of achieving HF bonding according to MIL STD 1310.

## 6 Technical description

Figure 6 shows the COSAMS pneumatic arrangement and Figure 7: the internal electrical arrangement.

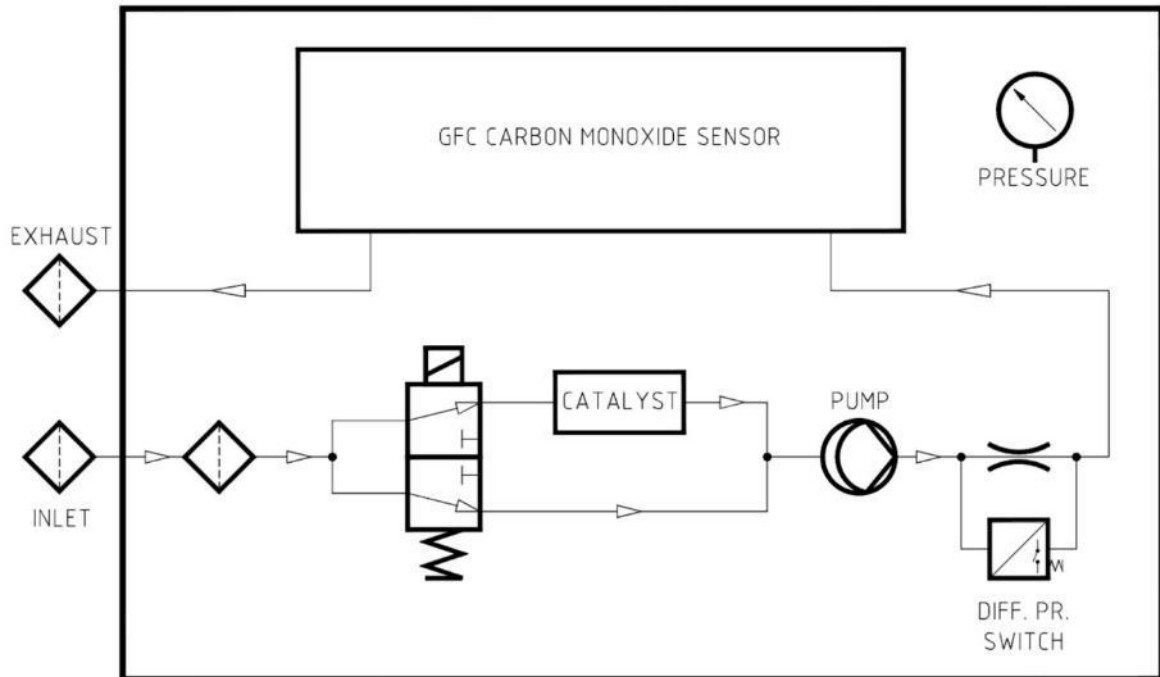

Figure 6 COSAMS internal pneumatic arrangement

### 6.1 Gas sampling

Sample gas is drawn in to the COSAMS through a push-in pre-filter in the underside of the cabinet and then passes through an internal particulate filter.

After filtering, the sample flows through a solenoid valve which is energised periodically to temporarily divert the sample through an extra loop of pipework. This extension to the gas path incorporates a canister containing a catalyst which removes any CO present in the sample stream, allowing the COSAMS to trim out any baseline signal drift.

The sample pump is downstream of the solenoid valve/catalyst and the output from the pump passes through an orifice restrictor to limit the rate of gas flow through the sensor. A pressure switch monitors the pressure drop across the restrictor and an absence of pressure drop is interpreted as a lack of sample flow. Gas exits the sensor's optical bench and exhausts through the outlet on the right-hand-side of the COSAMS cabinet.

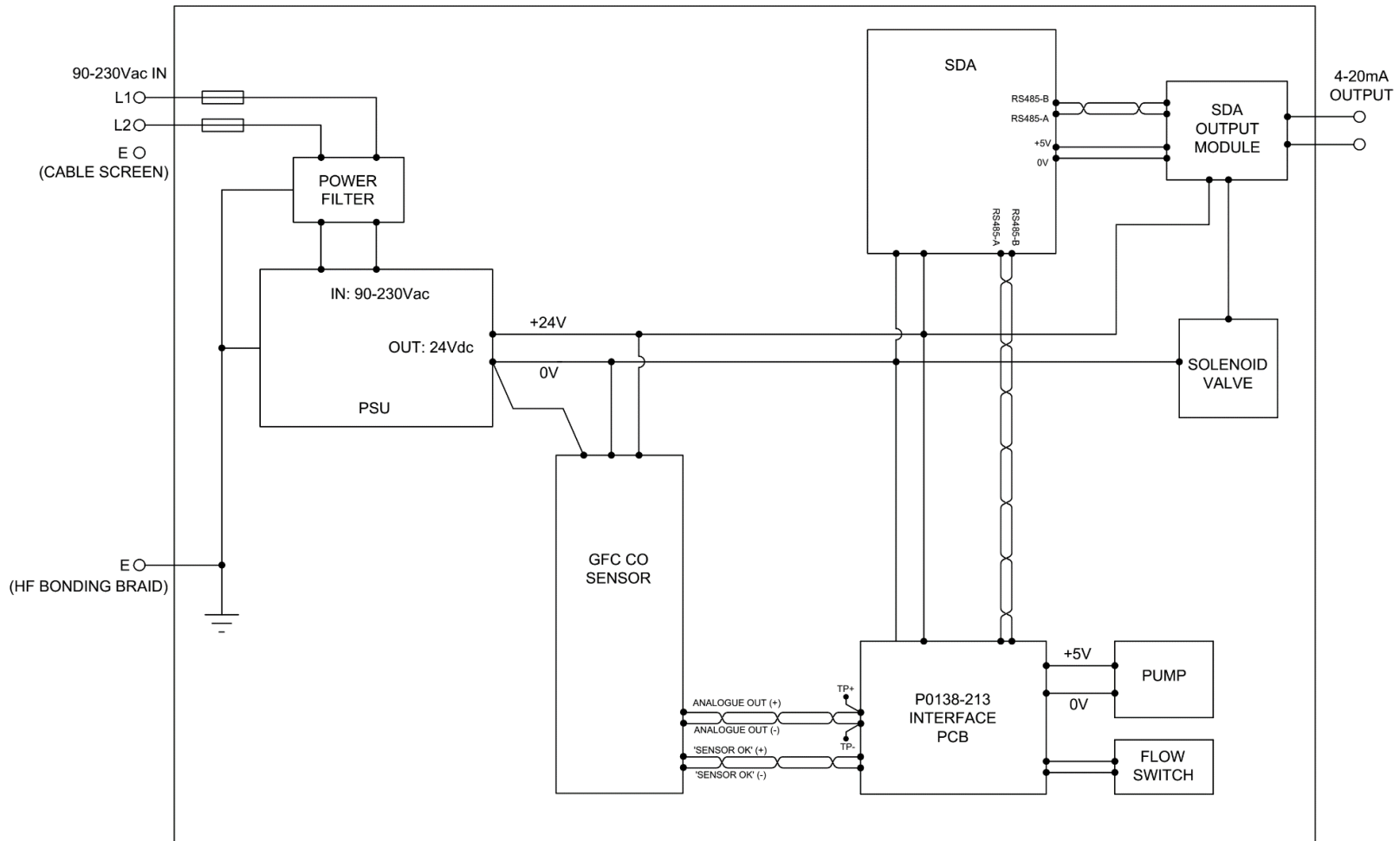

**Figure 7 COSAMS internal electrical arrangement (AC variant)**

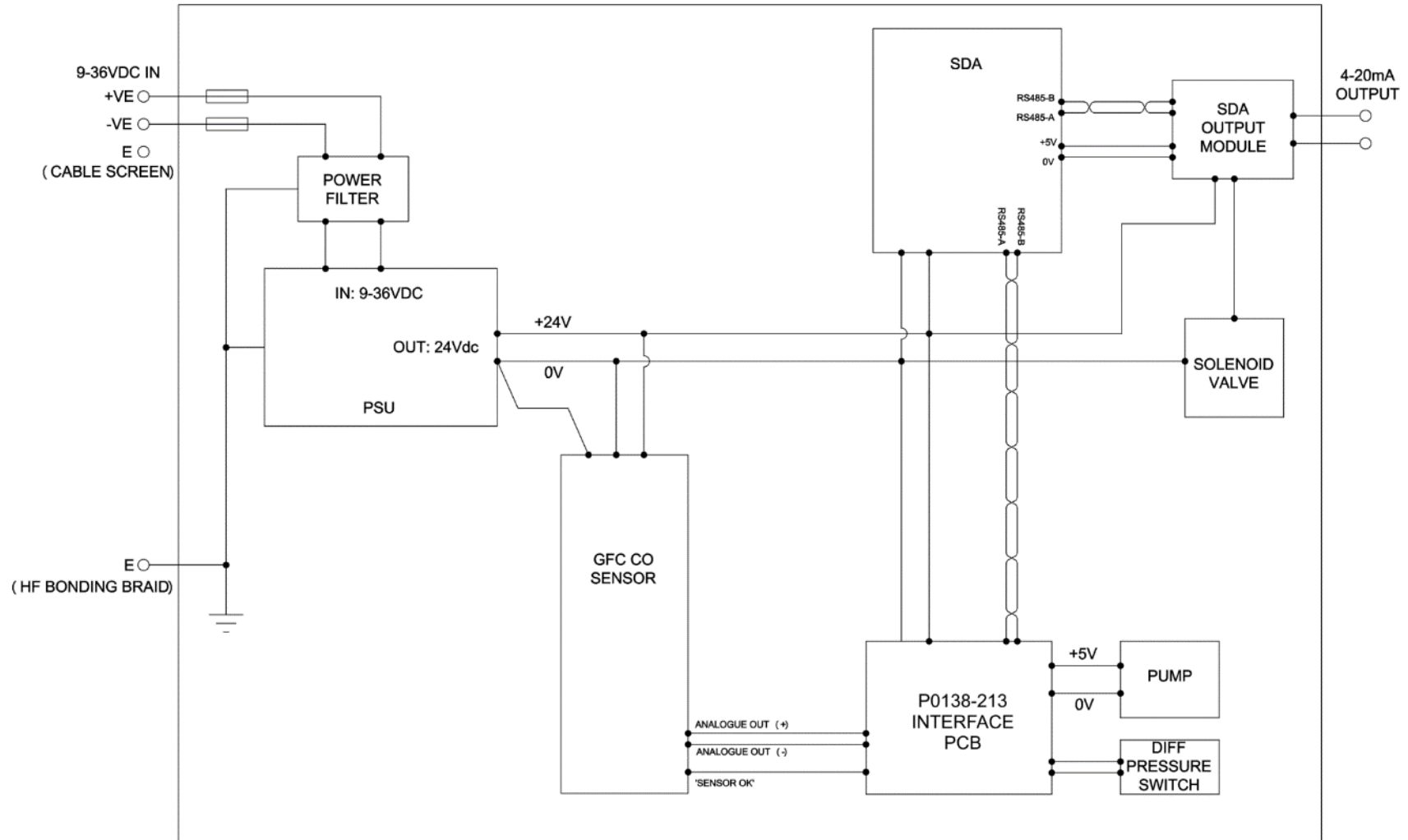

**Figure 8 COSAMS internal electrical arrangement (DC variant)**

## **6.2 Power supply**

The COSAMS can be supplied with either an AC power supply or a DC power supply, this should be stipulated at the time of order.

### **6.2.1 Power supply (AC variant)**

The COSAMS is powered from the boat's 115V, 60Hz AC supply. The screen of the incoming power cable is earthed at the supply end and connected to the shell of the cable connector, providing 360 degree EMC protection.

It is expected that the electrical supply will be floating with respect to the submarine hull, therefore both inputs (*L1* and *L2*) are fused. Fuses *F1* & *F2* are housed in externally-accessed, waterproof fuse holders mounted on the left-hand side of the COSAMS cabinet.

Power filtering is performed by a general purpose EMI filter for improved EMC performance. It should be noted that the filter has a 4.7nF capacitor between each line and ground; this level of capacitance to the submarine hull is permissible under MIL\_STD-461F, which imposes a 100nF limit.

The filtered supply then connects to a universal input (85 to 264V AC) isolated power supply unit (PSU) which generates a 24V DC supply to power the instrument. The PSU is rated for 70W continuous output; actual DC power consumption is typically 40W with a 55W maximum. Isolation in excess of 500V AC for 60s is provided from input to output, input to case (earth) and output to case (earth).

### **6.2.2 Power supply (DC variant)**

The COSAMS is powered from the boat's low voltage DC supply. The screen of the incoming power cable is earthed at the supply end and connected to the shell of the cable connector, providing 360 degree EMC protection.

It is expected that the electrical supply will be floating with respect to the submarine hull, therefore both inputs (+*VE* and -*VE*) are fused. Fuses *F1* & *F2* are housed in internally-accessed fuse holders mounted on the left-hand side of the COSAMS cabinet.

Power filtering is performed by a general purpose EMI filter for improved EMC performance.

The filtered supply then connects to a universal input (9 to 36V DC) isolated power supply unit (PSU) which generates a 24V DC supply to power the instrument. The PSU is rated for 150W continuous output; actual DC power consumption is typically 40W with a 55W maximum. Isolation in excess of 500V DC is provided from input to output, input to case (earth) and output to case (earth).

## **6.3 Power distribution**

The internally generated 24V DC supply is distributed to the following items:

- CO sensor
- Interface PCB
- SDA operator console
- Solenoid valve circuit for auto-zero calibration (via SDA output module relay contacts)

## **6.4 CO sensor**

The CO sensor measures CO concentration using the *gas filter correlation* (GFC) technique, making use of the infra-red absorption properties of CO. This technique is particularly well-suited to the submarine application as it yields no response to hydrogen (which produces false-positive readings from electrochemical sensors) and has negligible cross-sensitivity to water vapour (unlike standard non-dispersive infra-red absorption sensors).

The CO sensor sub-assembly is a 24V DC-powered device generating a non-linear DC voltage output related to the concentration of CO in its optical bench. This output voltage is fed in to the interface PCB where signal processing takes place.

CO sensor output is set to a nominal 0.8V in the absence of CO (0ppm) and 2.7V when subjected to 200ppm CO at 20°C, 1000hPa.

The CO sensor also supplies the interface PCB with a 'status' output, indicating whether the sensor is operating normally or if an internal fault has been detected.

**6.5 5S3 control interface**

The interface PCB measures the temperature and barometric pressure within the COSAMS cabinet and applies appropriate compensations to the CO sensor signal prior to calculating the CO concentration in the sample gas stream and reporting to the SDA operator console via an RS485 link (the 5-way connector plugged in to the SDA's *Sensor* socket).

The interface PCB monitors numerous operating parameters, including gas flow and the CO sensor's *Status* line, and reports any fault conditions to the SDA operator console.

The interface PCB also controls timing of the auto-zero function, directing the SDA operator console to energise the solenoid valve when required, and checks the outcome of the operation for plausibility. Other calibration adjustments are performed as directed by the SDA operator console. All sensor calibration data is stored within the interface PCB .

Power to the COSAMS gas sample pump is supplied by the 5S3's internal 5V rail.

**6.6 SDA operator console**

The SDA is the operator console, or user interface, for the COSAMS.

The SDA's LCD shows the 5S3-derived CO measurement and indicates the system status by the colour of left-hand corner of the display:

| Colour | Status                      |
|--------|-----------------------------|
| Green  | OK                          |
| Yellow | Fault detected              |
| Red    | CO alarm threshold exceeded |

The SDA operator console powers the SDA Output Module and communicates with it over an RS485 link (the 5-way connector plugged in to the SDA's *Data* socket), driving the analogue output to a value commensurate with the measured CO concentration and system status. The SDA also instructs the SDA Output Module to energise the solenoid valve when the interface PCB indicates that an auto-zero is to be performed.

The SDA provides the operator with access to calibration functions and also to logged data via the USB port on the rear of the console.

**6.7 SDA output module**

The Output Module is controlled by the SDA operator console which supplies 5V DC power and sets the 4-20mA output signal level (refer to Section 5.3.2 for details on the output signal).

The Output Module's *Normally Open* relay is energised to operate the COSAMS solenoid valve during the auto-zero operation.



6.8 Electrical schematic (AC variant)

The internal wiring of the COSAMS is shown in **Figure 9**

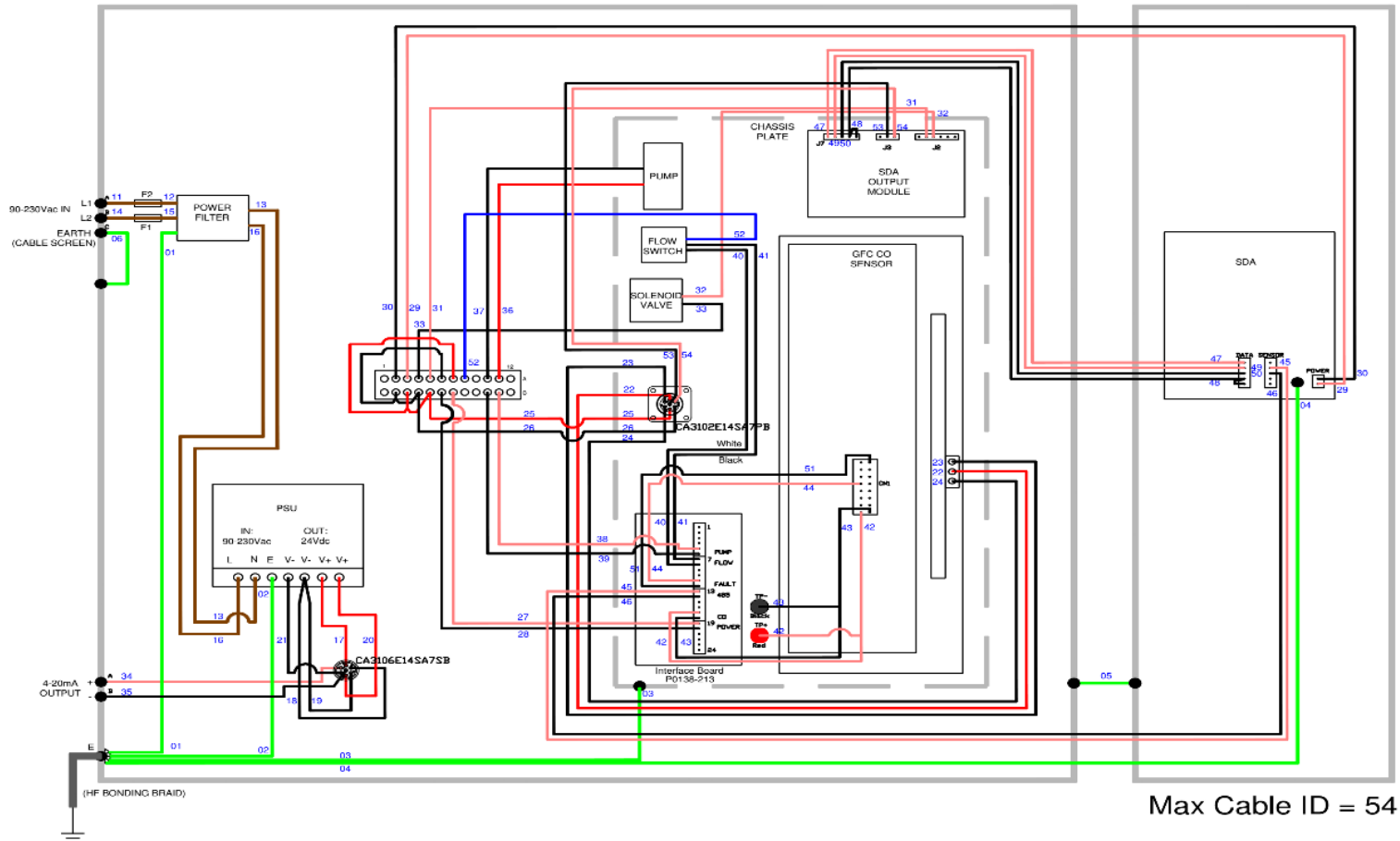
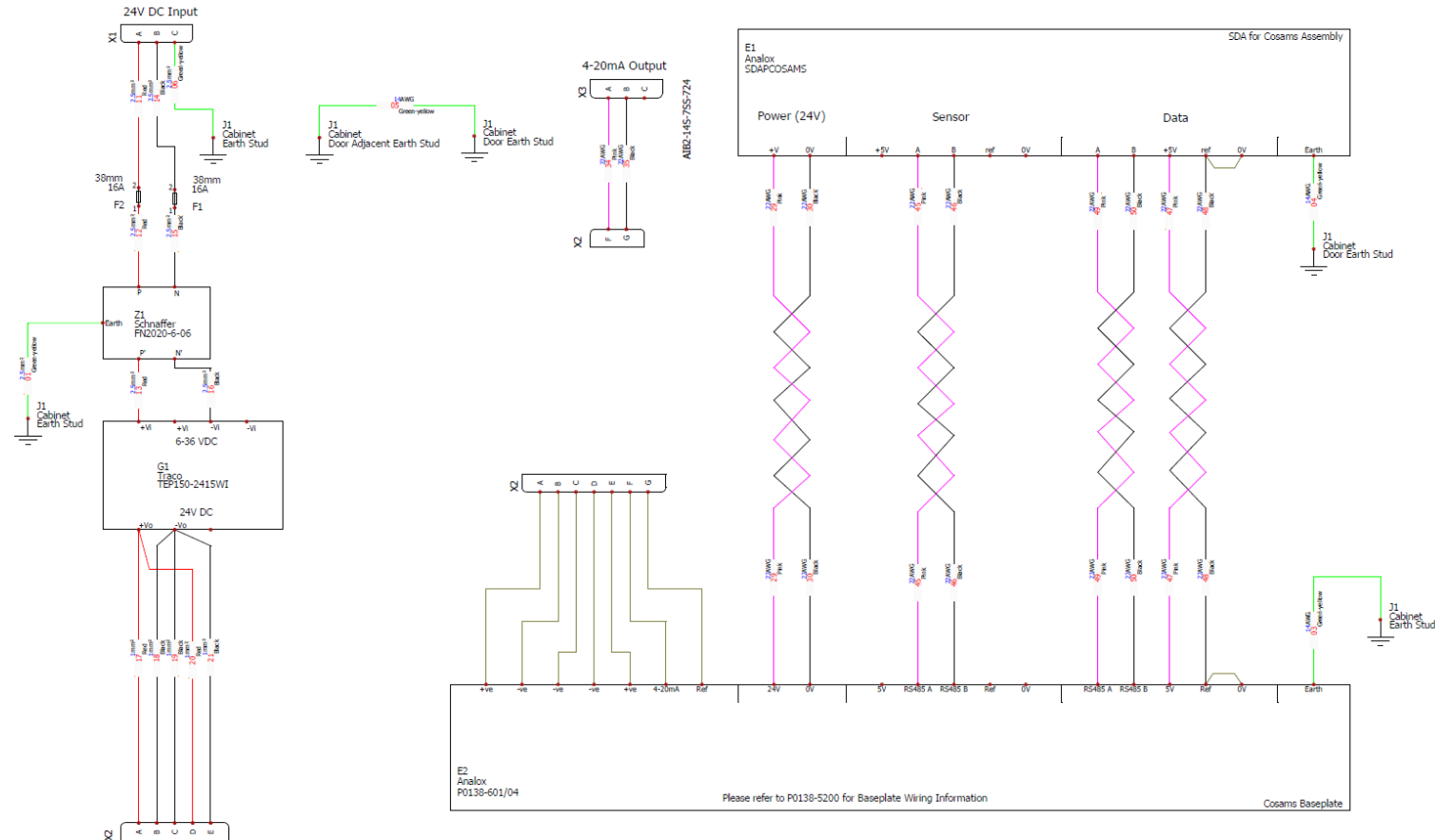

Figure 9 Internal wiring schematic (AC variant)

**6.9 Electrical schematic (DC variant)**

The internal wiring of the COSAMS is shown in **Figure 10** & **Figure 11**



**Figure 10 Internal Wiring Schematic (Cabinet) (DC variant)**

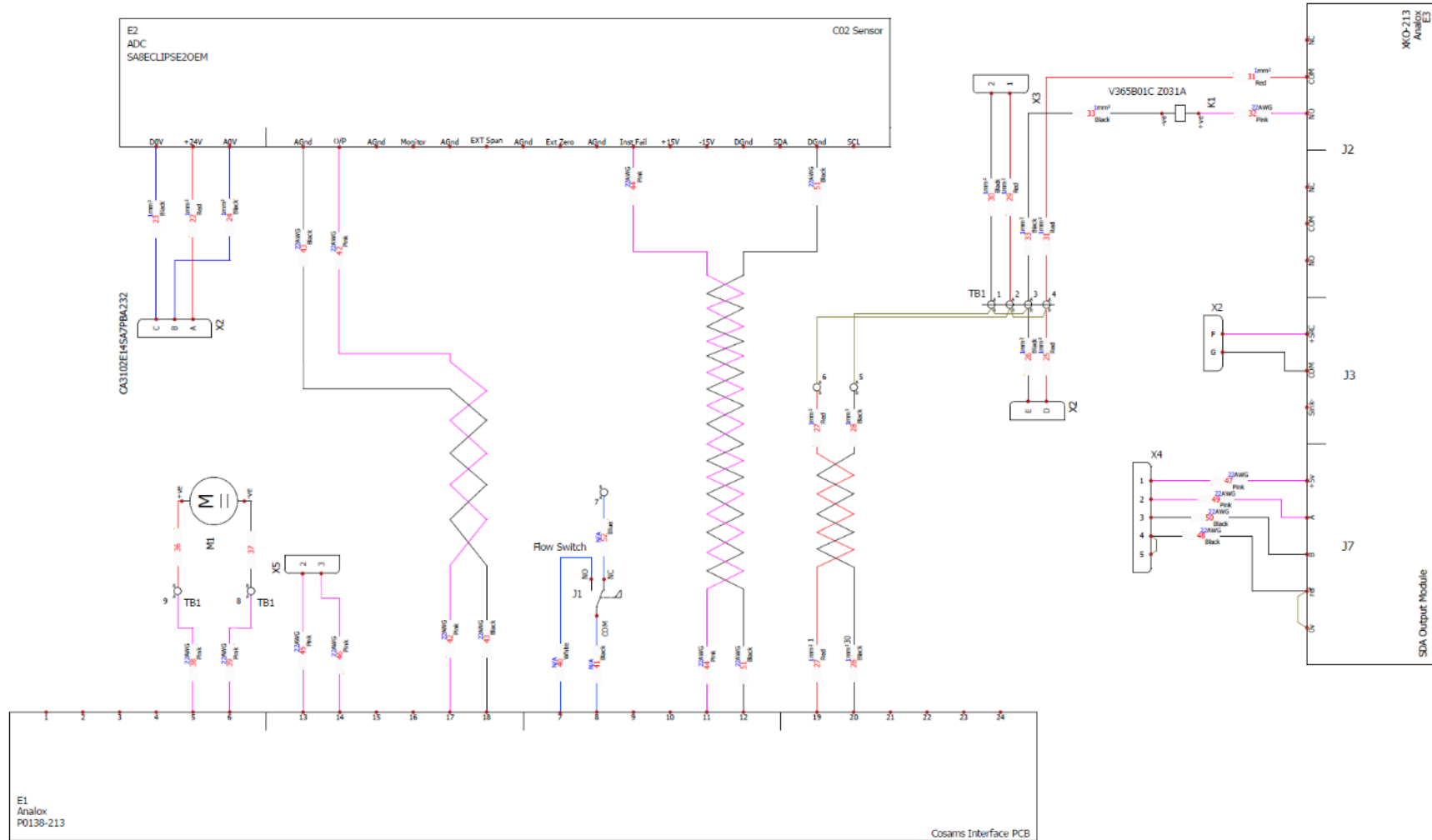

Figure 11 Internal Wiring Schematic (Baseplate) (DC variant)

## 7 Operating instructions

### 7.1 Controls

Figure 12 shows the COSAMS front panel:



Figure 12 COSAMS front panel

- 1 LCD
- 2 Rotary encoder
- 3 Mute/Cancel pushbutton
- 4 Menu/Set pushbutton
- 5 Alarm set point controls
- 6 Calibration controls

### 7.2 Start-up

The COSAMS will automatically start up when power is supplied to it. Initially, the COSAMS will display a splash screen as shown in **Figure 13**, below, for a few seconds:



Figure 13 Start-up splash screen

After displaying the splash screen, the LCD will go blank for approximately 15 seconds and then the 'normal' COSAMS operating screen will display.

**7.3 Warm-up**

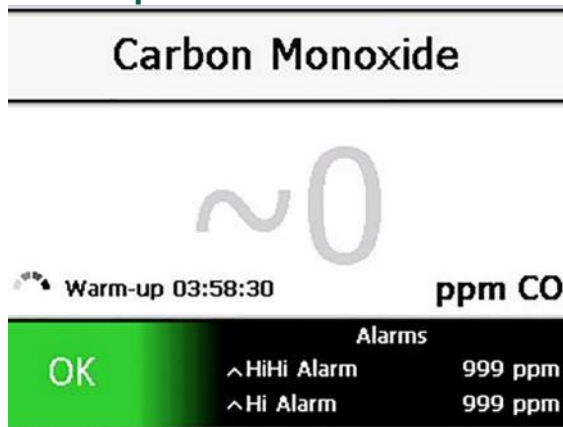

**Figure 14 Warm-up screen**

Upon start-up, the CO sensor requires a period of up to 4 hours to 'warm up' and achieve accurate readings. During this time, the screen will indicate that the sensor is in warm-up mode, displaying a countdown to normal operation, and the CO reading will be shown in grey text preceded by a "~" symbol (see 0), indicating that the value is approximate and should be regarded with a degree of scepticism.

The analogue output is clamped to the fault level during warm up.

In the event of a brief interruption to the COSAMS power supply, the system will enter a shortened warm-up period with duration being proportional to the time spent un-powered.

**7.4 Normal operation**

When the warm-up period has expired, the sensor reading will be shown in black text and the analogue output signal will reflect the measured concentration of CO.

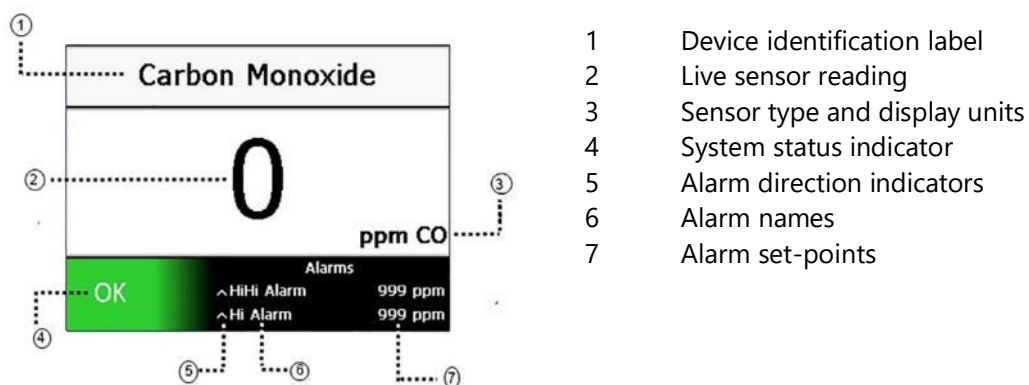

**Figure 15 Main display overview**

The live sensor reading is updated on the display approximately once per second. If no valid sensor reading is currently available then the last 'good' sensor reading will be displayed in grey text preceded by '~'.

**7.4.1 System status indicator**

The system status indicator shows the current status of the COSAMS system.

In normal operation, i.e. the absence of any alarm or fault conditions, the system status indicator will be green and read 'OK'.

If any alarm condition has been identified then the system status indicator will turn red and display the word 'Alarm'.

If a system fault is detected then the status indicator will turn yellow and display the word 'Fault'.

The system indicator also uses icons to show system diagnostic information:



**Fault.** This icon indicates that a fault has been identified within the system. This icon will be accompanied by a status code. See troubleshooting section for further information on the specific condition. This icon will flash when a new fault condition is identified and until the fault is acknowledged by pressing the mute button.



**Processing.** This animated icon indicates that the sensor module is performing some internal function, such as calibration.

## 7.5 Menu

The main menu can be accessed from the main screen by pressing the Menu pushbutton:

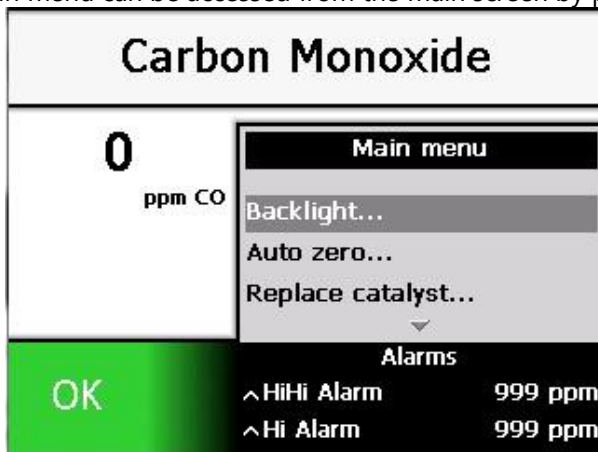

**Figure 16** The main menu

An arrow at the top or bottom of a menu indicates that there are more menu options above or below those currently shown.

To select a menu item, rotate the encoder to highlight the required option and press 'Set' to select the highlighted item.

Selecting certain menu items will result in a sub-menu being displayed. Selecting the back option from a sub-menu will return to the previous menu level.

The 'Cancel' pushbutton can be pressed at any time whilst using the menu to exit from the menu.

The menu options available are listed in **Table 8**

| Menu item           | Purpose  |
|---------------------|--|
| Backlight...        | Control the intensity of the display backlight             |
| Auto-zero...        | Instruct the COSAMS to perform an auto-zero calibration    |
| Replace catalyst... | Instruct COSAMS that a new catalyst module has been fitted |
| Service...          | Instruct the COSAMS that a service has been completed      |
| Information         | Access system information                                  |
| Data logging        | Access options to manage data log information              |
| Exit                | Exit from menu and return to normal operating screen       |

**Table 8** SDA operator console menu items

### 7.5.1 Adjusting the backlight

The brightness of the COSAMS display can be changed to suit the local lighting conditions by adjusting the backlight intensity.

Selecting the 'Backlight' option from the main menu results in the 'Set backlight' sub-menu being displayed. Highlight the desired backlight intensity level (10 to 100%) and press the *Menu/Set* pushbutton.

To exit from the sub-menu without changing the backlight intensity, either press the *Mute/Cancel* pushbutton or select the 'Back' option to return to the main menu.

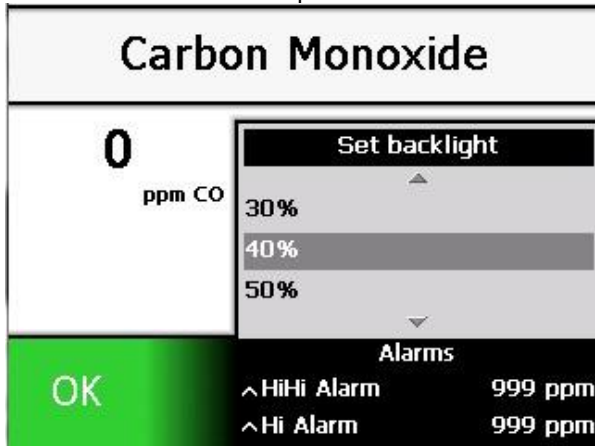

Figure 17 The backlight sub-menu

- ⚠ **CAUTION:** DUE TO THE NATURE OF THE DISPLAY TECHNOLOGY, THE MAXIMUM INTENSITY OF THE DISPLAY WILL DEGRADE SLIGHTLY OVER THE LIFESPAN OF THE PRODUCT. FOR NEW SYSTEMS IT IS RECOMMENDED THAT THE BACKLIGHT IS SET TO AN INITIAL INTENSITY LEVEL OF 60% OR LESS TO MAXIMISE THE LIFESPAN OF THE DISPLAY.

### 7.5.2 Auto-zero function

The auto-zero function is initiated automatically after the COSAMS warm-up period has expired and then periodically thereafter to trim out any drift in the sensor's baseline output. The user may also manually initiate an auto-zero operation via the menu option, allowing a zero calibration to be performed when a technician does not have access to zero calibration gas.

During the auto-zero process, the solenoid valve is energised to divert flow through the catalyst module, scrubbing the gas of any CO by oxidising to CO<sub>2</sub>. The COSAMS will not monitor ambient CO concentration whilst engaged in the auto-zero so the CO reading will be displayed in grey and preceded by the '~' symbol; the 4-20mA signal level will be maintained at the same level as immediately prior to starting the auto-zero.

Factory default timings for the auto-zero operation are:

Period between auto-zeroes: 6 hours

Auto-zero duration: 3 minutes

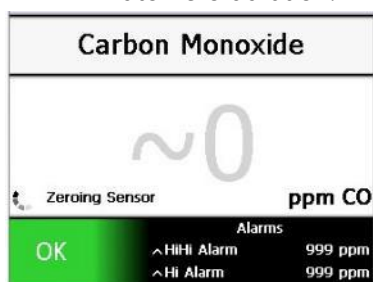

**Figure 18 Zeroing sensor indication**

### 7.5.3 Replacing catalyst

If the COSAMS rejects an auto-zero result due to a suspected problem with the catalyst, the ensuing fault announcement (see **Table 9**) can be cleared by selecting the *Replace catalyst...* option.

### 7.5.4 Resetting the service interval timer

After servicing the COSAMS, the service interval timer may be reset to 1 year by selecting the *Service...* option.

### 7.5.5 COSAMS information

An information screen can be accessed to check the configuration of the system. From the Main Menu, select the 'Information' option.

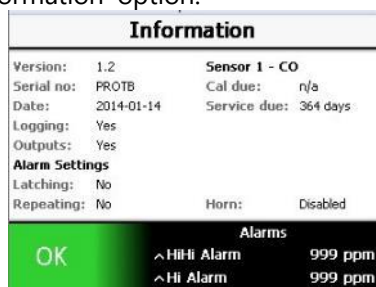

**Figure 19 COSAMS information screen**

This screen shows the software version number, the instrument serial number, various settings, and the time until a service is due.



### 7.5.6 Data logging

The SDA unit logs measurement data over a 90-day period at 10-second intervals. The following parameters are logged:

1. System status
2. Average CO reading over the last 10s period
3. Minimum CO reading during the last 10s period
4. Maximum CO reading during the last 10s period

When the log is full, i.e. 90 days of data has been collected, the oldest data is over-written such that the log contains a continuous record of the preceding 90 days.

#### 7.5.6.1 Downloading logged data

Logged data is available to the user via the USB port located on the rear of the SDA. The data provides the following information:

|            |          |    |     |   |   |   |
|------------|----------|----|-----|---|---|---|
| 08/01/2014 | 12:44:16 | OK | ppm | 0 | 0 | 0 |
| 08/01/2014 | 12:44:26 | OK | ppm | 0 | 0 | 0 |

**Figure 20 Example of data logged by system**

To download logged data:

- [1] Plug a USB flash drive into the USB port on the SDA (this is on the rear of the enclosure door - see the photograph below):**



- 1] Go to the SDA operator console on the front of the enclosure door.
- 2] Press the Menu/Set button, then scroll through the options using the rotary encoder.
- 3] Press the Menu/Set button again to select the 'Data logging' Menu option.
- 4] Press the Menu/Set button again to select 'Download data to USB...' Data will download to the USB flash drive, with one CSV file for each day of data. When download is complete, the files can be imported directly to Microsoft Excel or similar spreadsheet packages.

To delete logged data:

- 1] Press the Menu/Set button, then scroll through the options using the rotary encoder.
- 2] Press the Menu/Set button again to select the 'Data logging' Menu option.
- 3] Press the Menu/Set button again to select 'Delete all data-logs'. All logged data will be deleted.

To download logged data using the Data Download Tool (DDT) (Analox branded USB stick):

- 1] **When using the Data Download Tool the files stored on the COSAMS device will not be affected.**
- 2] **Open the COSAMS enclosure using the supplied cabinet key**



- 3] **Locate the USB "TECH" port on the rear of the SDA Operator Console (SOC) and fit the DDT**



- 4] **Locate and unplug the power supply cable in the back of the SOC designated by idents 30 (black wire) and 29 (red wire). After a minimum period of 5 seconds reconnect the power supply cable in the back of the SOC.**



- 5] **Check the SOC display shows the device splash screen. After a short period the splash screen will go blank before the DDT Diagnostic & Fault Extractor software starts.**

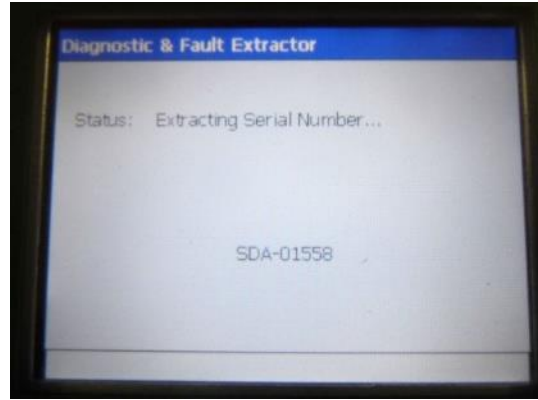

6] This will automatically download the device datalogs, Once datalog download is complete the device will start downloading diagnosis logs

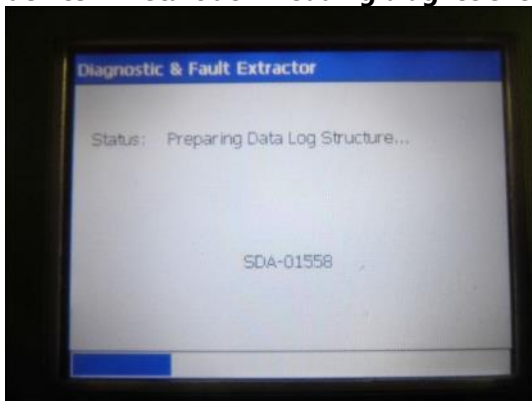

7] Once datalogs finish the fault log download will start.

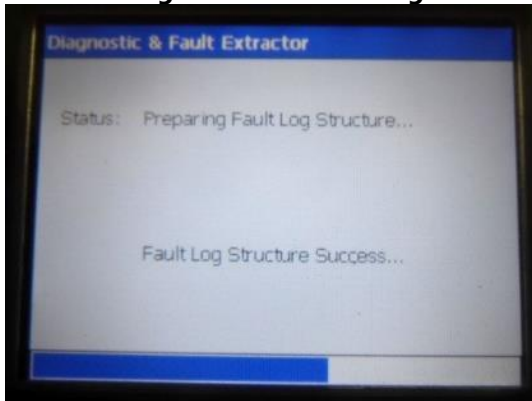

- 8] Once all downloading is complete the Status will show as finished and request the USB device to be removed.



- 9] Once the USB device is removed, close the COSAMS cabinet door and lock.

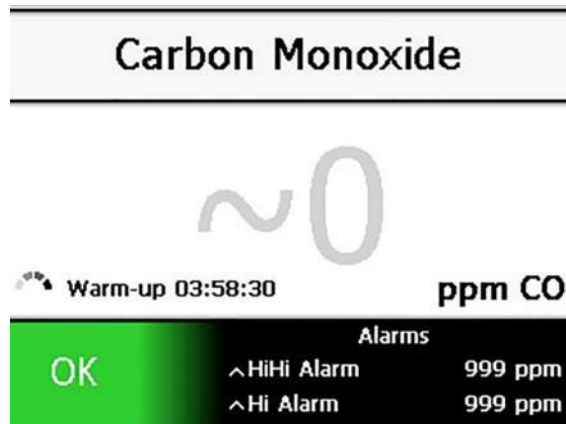

- 10] The SOC will automatically reboot and enter a reduced COSAMS warm up period prior to normal operation mode.

## 8 Calibration

-  **CAUTION:** **INCORRECT USE OF CALIBRATION GAS CAN ADVERSELY AFFECT THE INSTRUMENT'S PERFORMANCE. ONLY TRAINED PERSONNEL SHOULD ATTEMPT CALIBRATION.**

It is intended that the COSAMS be calibrated immediately prior to a sortie or every 30 days to maintain accuracy. The auto-zero function, described in section 7.5.2, maintains accuracy during the period of the patrol.

### 8.1 Zero and span calibration

Two gases are required to calibrate the COSAMS, *zero* gas (0ppm CO) and *span* gas (a high concentration of CO in air balance), as detailed in section 12.2.

*Zero* gas calibration should be performed first, followed by *span* gas calibration.

-  **NOTE:** **THE COSAMS MONITORS THE AMBIENT AIR AT THE GAS INLET TO THE INSTRUMENT, USING AN INTERNAL PUMP TO DRAW A GAS SAMPLE THROUGH THE SENSOR.**

Calibration gas may be connected to the sample inlet while calibrating, provided it is controlled by a suitable regulator as described in section 8 and section 12.4.8.

Gas pressure at the inlet port must not exceed 500hPa (gauge pressure).

Do not obstruct the exhaust port.

#### 8.1.1 Performing a zero calibration

- 1] Remove the push-fit pre-filter in the gas inlet and supply the COSAMS with zero gas at a flow rate of 0.5 – 0.7 lpm via Ø6mm tubing.
- 2] Maintain the gas flow for approximately 3 minutes, by which time the COSAMS CO reading should have reached a steady value.
- 3] Press and hold the *Zero Calibrate* pushbutton and press the *Menu/Set* pushbutton to initiate the calibration. Releasing the *Zero* pushbutton before pressing *Menu/Set* will abort the calibration and return the COSAMS to normal operation.
- 4] The COSAMS will attempt a calibration, resulting in either a 'Calibration OK' or a 'Calibration failed' message as shown in 0
- 5] Press the *Mute/Cancel* button to clear any calibration messages that may remain on-screen.

### 8.1.2 Performing a *span* calibration

- 1] Switch from *zero* gas flow to *span* gas flow and maintain 0.5 – 0.7 lpm flow rate for approximately 3 minutes, by which time the sensor reading should have reached a steady value.
- 2] Press and hold the *Span Calibrate* pushbutton; the calibration value entry panel will be shown (0) with the cal. gas CO concentration displayed in blue.
- 3] Use the rotary encoder to adjust the value to the CO concentration in the calibration gas.
- 4] Press the *Menu/Set* pushbutton to initiate the calibration. Releasing the *Span* pushbutton before pressing *Menu/Set* will abort the calibration and return the COSAMS to normal operation.
- 5] The COSAMS will attempt a calibration, resulting in either a 'Calibration OK' or a 'Calibration failed' message as shown in 0 below.
- 6] Press the Mute/Cancel button to clear any calibration messages that may remain on-screen.

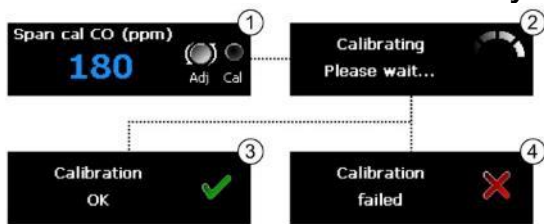

Figure 21 *Span adjustment*



## 9 Alarms

The COSAMS can provide two alarm indications, triggered on detection of a high level (*Hi*) of CO and very high level (*Hi Hi*). COSAMS is supplied with these alarm thresholds set at 999ppm CO, effectively disabling alarm annunciation. It is possible to bring the alarms in to use by adjusting the alarm set points to within the COSAMS' range of measurement, as described in section 9.1.

Alarm annunciation is limited to visual indication on the SDA operator console: the system status indicator will flash red and display 'Alarm', the measured CO concentration will be displayed in red text and the relevant alarm set point will display in red text. Audible alarm annunciation is inhibited.

The 4-20mA output signal is completely unaffected by alarm state.

### 9.1 Adjusting alarm set points

If desired, the user may adjust the set point(s) to within the CO measurement range, thereby activating the alarm(s).

**NOTE:** IF THE SDA OPERATOR CONSOLE IS USED TO ACTIVATE THE ALARMS IN THE MANNER DESCRIBED BELOW THEN THE TECHNICAL IN-SERVICE SUPPORT SOFTWARE DESCRIBED IN SECTION 33 WILL BE REQUIRED TO RETURN THE SET POINTS.OUT-OF-RANGE; THE MAXIMUM SET POINT VALUE ACHIEVABLE VIA THE OPERATOR CONSOLE IS 200PPM CO.

To adjust a set-point, press and hold the relevant alarm-adjust pushbutton - top button for *Hi Hi* alarm, bottom button for *Hi* alarm. The alarm adjustment panel will be shown at the bottom of the LCD, alongside the system status indicator. The panel shows the name of the alarm to be adjusted and the current alarm set-point in yellow (**Figure 22**).

Keep the alarm-adjust pushbutton depressed and use the rotary encoder to adjust the set-point: turn clockwise to increase, anti-clockwise to decrease.

**NOTE:** TO QUICKLY REDUCE THE ALARM SETTING FROM THE INITIAL 999PPM SETTING, SIMPLY ATTEMPT TO ADJUST THE SETPOINT UPWARDS (CLOCKWISE). THE VALUE WILL THEN SNAP TO 200PPM, FROM WHERE IT CAN THEN BE ADJUSTED NORMALLY.

When the desired set value is reached, keep the alarm-adjust pushbutton depressed and press the *Menu/Set* pushbutton to accept it; the value will turn green, indicating confirmation of the new set point and the alarm-adjust push button can be released.



**Figure 22** Example of alarm set-point adjustment

**NOTE:** RELEASING THE ALARM-ADJUST PUSHBUTTON PRIOR TO CONFIRMATION WILL RETURN THE SET POINT TO ITS ORIGINAL VALUE.

### 9.2 Acknowledging alarms

COSAMS alarms are latching meaning that, once triggered, the alarm annunciation will continue until acknowledged by an operator, even if the CO concentration returns to a low level.

Alarms are acknowledged by pressing the *Mute / Cancel* pushbutton.

If the alarm condition no longer exists when the alarm is acknowledged then the LCD will revert to its normal operating condition upon acknowledgement, otherwise, the system status indicator will remain red but cease to flash, the CO will still be displayed in red, as will the appropriate alarm set point. Only when the alarm condition has cleared will the display revert to normal operation.

### 9.3 Clearing alarms and hysteresis

An alarm will always trigger immediately when the sensor reading exceeds an alarm set point. However, to avoid nuisance re-triggering of alarms when a sensor reading is fluctuating around an alarm set point, the CO level must drop a certain amount below the set point before an acknowledged alarm will clear. This difference between the alarm set point and the lower CO level at which an acknowledged alarm will clear is the alarm's hysteresis.

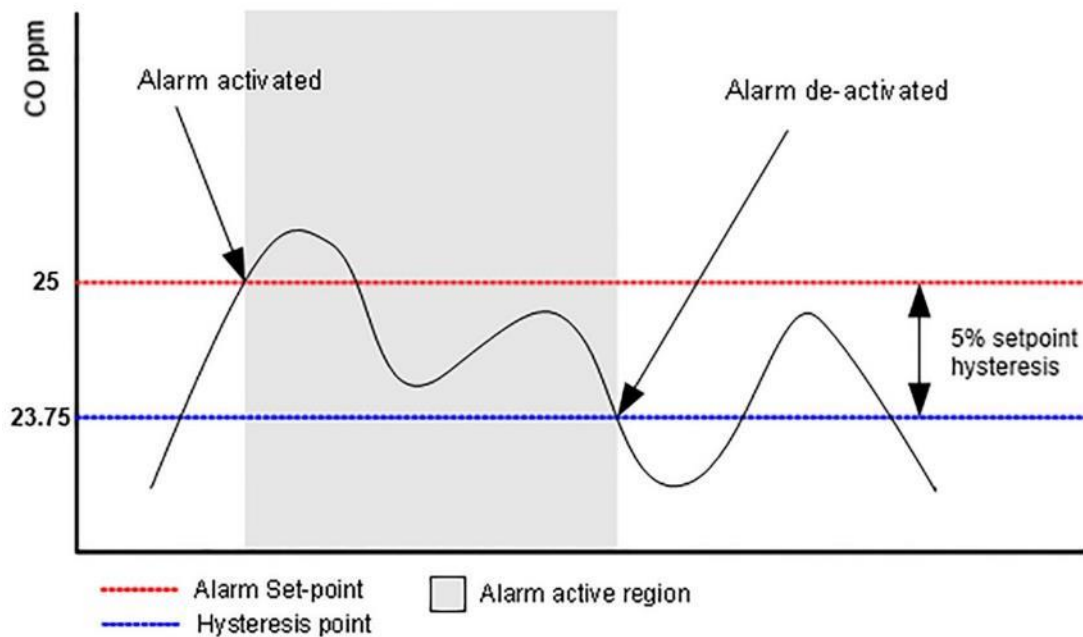

**Figure 23 Alarm hysteresis**

The hysteresis applied to an alarm is calculated as a percentage of the set point value with an upper limit imposed.



## **10 Technical in-service support software**

COSAMS SDA software is provided to allow the device to be configured using a USB connection. The software is designed to run on Microsoft Windows®. Please refer to the COSAMS Software Manual P0138-812 contained on the COSAMS Software CD.

The utilities on the CD are not required in normal use but may be of benefit in the event of in-service support being required.

## 11 Troubleshooting

### 11.1 Fault announcement

The COSAMS constantly monitors for fault conditions; any that are identified will trigger a fault announcement.

The system status indicator will flash yellow, and the 4-20mA signal will be set to ~2mA.

Fault announcements can be acknowledged by pressing the *Mute/Cancel* button; the system status indicator will cease to flash and analogue output will remain high until the fault condition is rectified.

All fault announcements are latching; if an intermittent fault condition is identified and subsequently clears (e.g. gas flow is temporarily interrupted), the fault announcement will continue until it has been acknowledged.

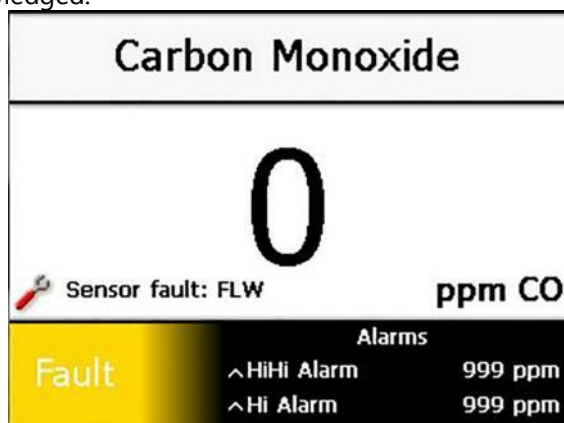

**Figure 24** Fault indication (example of a flow fault)

### 11.2 Fault diagnosis

Information about the fault condition is displayed just below and to the left of the CO reading, as shown in **Figure 24**.

In cases where a fault prevents a valid reading from being obtained from the sensor, then the last good reading will be shown in grey, preceded by '~'.

### 11.3 Fault logging

All instances of fault conditions that are identified will be logged to the COSAMS's diagnostics log (both the point at which the fault is identified and the point at which the fault is cleared will be logged).

The diagnostics log can be downloaded using the COSAMS SDA software.

Please refer to the COSAMS Software Manual P0138-812 contained on the COSAMS Software CD for information on how to access this.

**Table 9** shows a full list of fault messages together with a description of the cause and suggested remedies.

| <b>Fault message</b> | <b>Cause</b>   | <b>Solution</b>   |
|----------------------|--|---|
| Sensor fault: OMF    | Unable to establish communications between SDA and Output Module via RS485 communication link.   | Check integrity of comms connections on SDA and Output Module. If connections are satisfactory but fault persists, replacing the Output Module or the SDA Operator Console may solve the problem.   |
| Sensor fault: ACZ    | The auto-zero calibration process did not complete successfully:<br>- the sensor output has drifted too far from its initial value or<br>- another fault condition, which might prevent correct calibration, was detected during the procedure | Check calibration of sensor using zero gas (section 12.4.8). If catalyst is OK, then this should also result in a calibration fault. If catalyst is the problem, then calibrate with zero gas should succeed. To identify whether or not the catalyst is the source of the problem, first ensure that the switching solenoid is operating. The solenoid valve is switched by a relay in the Output Module, so ensure that power is reaching the solenoid valve via the Output Module relay. If all OK, but auto-zero still fails, then replace catalyst module. |
| Sensor fault: CAT    | The auto-zero calibration did not complete successfully, the calculated adjustment required has changed by an unacceptable amount since the previous auto-zero.  | Check operation of the solenoid valve. If the valve is switching satisfactorily, replace the catalyst module. Reset the catalyst fault from the main menu as detailed in section 12.3.2.  |
| Sensor fault: CRC    | Code or data corruption within interface PCB.  | Should the interface PCB need to be replaced, contact Analox.   |
| Sensor fault: FLW    | Defective flow switch or insufficient gas flow caused by any of:<br>- Blocked inlet filter<br>- Blocked outlet filter<br>- Blocked internal filter<br>- Defective pump<br>- No electrical supply to pump<br>- Internal pipework leak           | Check pump is running – if it isn't, check that 5V DC supply from interface PCB is good.<br>Check inlet, outlet pre-filters and internal filter for line blockage.<br>Check pipework connections are good.<br>Check flow switch operation.  |
| Sensor Fault: ICF    | The 5S3 control interface has detected a low level on its 'GFC OK' signal line.  | Check integrity of the 'GFC OK' signal wiring.<br>If connection between the GFC sensor and 5S3 control interface PCB is good then contact Analox.   |
| Sensor comms fault   | Communications between SDA and interface PCB have been interrupted/lost.   | Check integrity of comms connections on SDA and interface PCB.. If connections are satisfactory but fault persists then contact Analox.   |
| Sensor fatal error   | Interface has experienced a fatal error.   | Should the interface PCB need to be replaced, contact Analox.   |

| <b>Fault message</b>    | <b>Cause</b>  | <b>Solution</b>  |
|-------------------------|---|--|
| Sensor fault: NFF       | An unexpected non-fatal fault has occurred.   | Note the occurrence of the alarm and report to Analox together with any information which may be relevant. Acknowledge the fault and attempt to continue operating.                                    |
| Sensor Fault: PWR       | The interface PCB's internally generated 5V DC is out of specification.               | Condition may be caused by faulty pump which is powered by the interface PCB's 5V DC rail. If pump is OK the interface PCB may need replacing; contact Analox.   |
| Sensor range fault      | The CO reading is below the expected minimum value.                                   | Recalibrate using SDA operator console. If fault persists, perform a 'coarse' calibration, as described in section 12.4.8. If this cannot be achieved, contact Analox.                                 |
| Sensor range fault: NFF | The interface PCB has reported a pressure reading falling outside the expected range. | If the pressure is considered within the normal range, then contact Analox.  |
| Sensor fault: TMP       | Unit is operating outside the operating temperature range.                            | Check ambient temperature – if within the COSAMS operating range then contact Analox.  |
| Pressure: PRE           | Pressure is outside the range of the unit.  | Note the occurrence of the alarm and report to Analox together with any information which may be relevant. Acknowledge the fault and attempt to continue operating.                                    |
| Initialisation: INT     | System has not initialised correctly  | Note the occurrence of the alarm and report to Analox together with any information which may be relevant. Acknowledge the fault and attempt to continue operating.                                    |
| Noise: NSY              | Outside of power supply unit's operating range.                                       | Check the power supply unit (PSU). Note the occurrence of the alarm and report to Analox together with any information which may be relevant. Acknowledge the fault and attempt to continue operating. |
| CRC error: CRC          | Flash memory is corrupt.  | Note the occurrence of the alarm and report to Analox together with any information which may be relevant. Acknowledge the fault and attempt to continue operating.                                    |

**Table 9** *Fault codes*

## 12 Maintenance

### 12.1 Spare parts

**Table 10** shows spare parts available to order:

| Item | Description   | Analox part number   |
|------|---|----------------------|
| 1.   | Power input connector (To be ordered with item 3)           | 2535-0114            |
| 2.   | Signal output connector (To be ordered with item 3)         | 2535-0115            |
| 3.   | Heatshrink boot   | 2535-0116            |
| 4.   | Carbon Monoxide Detector (COSAMS) Locking Key (Triangular)  | E3-3-1               |
| 5.   | USB lead  | 9300-1008            |
| 6.   | COSAMS software CD  | P0138-907            |
| 7.   | COSAMS User Manual  | Dependant on version |
| 8.   | Case breather   | 9456-1538            |
| 9.   | Power filter  | Dependant on version |
| 10.  | Fuse holder   | Dependant on version |
| 11.  | Fuse  | Dependant on version |
| 12.  | Power supply  | Dependant on version |
| 13.  | Sample Pump Kit (Includes Pump & Mounting Hardware)         | DD1COSAMSPK-MOD03    |
| 14.  | Solenoid valve  | 6000-0194            |
| 15.  | Flow Sensor (Inc. Mounting Bracket & Push Fit Elbows)       | FS6202CV-1M-COSAMS   |
| 16.  | Analox COSAMS SDA operator console                          | Dependant on version |
| 17.  | SDA Output Module PCB                                       | XK0-213-COSAMS-00    |
| 18.  | Gas inlet/outlet pre-filter                                 | 6000-0193            |
| 19.  | Catalyst assembly (internal)                                | P0138-603            |
| 20.  | Replacement internal filter element and O-ring (Pack of 10) | 2533-1100            |
| 21.  | Infra-red source for GFC CO sensor                          | 5000-0254-0021       |
| 22.  | Door EMC Gasket (Supplied in 1 metre lengths)               | 2321-0117            |
| 23.  | COSAMS membrane switch label                                | P0138-407            |
| 24.  | Baseplate assembly including sensor                         | Dependant on version |

| Item | Description  | Analox part number |
|------|--|--------------------|
| 25.  | COSAMS Data Download Tool (DDT)                          | COSAMS DDT         |
| 26.  | Potentiometer Adjustment Tool                            | 0000-0181          |
| 27.  | Replacement internal filter element, 5um (Pack of 10)    | 2533-1100          |
| 28.  | Air Suction Filter, 100 Series, 6mm Push, Filtration 5um | 2533-1009          |

**Table 10 COSAMS spare parts list**

Sundry minor fasteners and pneumatic items can also be supplied, if required. Please contact Analox for further information.

## 12.2 Special maintenance equipment

Besides common hand tools (screwdrivers, spanners, multi-meter, etc.), Analox recommend that the following equipment is available for maintaining the system and ensuring optimal performance:

| Item | Description   |
|------|---|
| 1    | Analox COSAMS software CD (supplied with system)  |
| 2    | USB cable (supplied with system)  |
| 3    | PC or laptop running Windows XP or later for use with Analox software (not supplied by Analox)          |
| 4    | Zero calibration gas: 20.9% oxygen in nitrogen recommended (to be sourced locally)                      |
| 5    | Span calibration gas: 150ppm CO in air recommended (to be sourced locally)                              |
| 6    | Demand flow regulator required for calibration gas bottles; required flow rate is approximately 0.6 lpm |
| 7    | Calibration gas hose (COSAMS gas inlet accepts 6mm outside diameter)                                    |

**Table 11 Special maintenance equipment**

Choice of calibration gas bottle will be subject to preference, being a compromise between storage space requirements, portability and capacity/longevity.

Analox recommend that a fairly small bottle is chosen, allowing the gas to be carried on board the submarine. For example, in the UK we would recommend the use of 110 litre S-Can bottles (360mm long x Ø86mm, 1.55 litres water capacity, fill pressure of 68 bar).

A demand flow regulator, suitable for use with instruments that use a pump to draw a sample should be used to deliver gas to the COSAMS. Flow rate will be in the region of 0.6 lpm.

150ppm CO in air is recommended for performing span calibration; this concentration has been chosen to match that used for calibrating previous CO sensors. Any CO concentration in the range 120 – 200ppm CO could be used, if required.

**12.3 Periodic maintenance**

**NOTE:** A RECOMMENDED SPARES AND MAINTENANCE INTERVALS GUIDE WILL BE INCLUDED WITH THE PRODUCT (DOCUMENT NUMBER P0138-918). THIS INCLUDES RECOMMENDED MAINTENANCE INTERVALS AND REPLACEMENT PART NUMBERS. WE RECOMMEND THIS DOCUMENT IS USED TO TRACK ANY MAINTENANCE CARRIED OUT ON THE COSAMS.

The Analox COSAMS has been designed to require minimal maintenance and minimal spare parts inventory. Most elements of the system maintenance can be carried out by Level 1 (on board maintenance personnel). Level 3 (contractor maintenance) should only be required during either safety control maintenance or main overhaul.

The following have been identified as on-board maintenance tasks that are required to ensure optimal operation, all tasks can be performed by submarine technical personnel:

| Item | Task   | Frequency   |
|------|--|---|
| 1    | Check condition of inlet & outlet pre-filters and internal filter. Replace as necessary (12.3.1) | Initially per mission, but expected to be relaxed to every 6 months |
| 2    | Sensor calibration   | Pre-deployment or 6 monthly   |
| 3    | Replacement of sample pump (12.3.5)  | 12 months   |
| 4    | Replacement of auto-zero catalyst module (12.3.2)  | 3 months  |
| 5    | Check condition of cabinet breather port and replace if necessary (12.3.3)                       | 2 years   |
| 6    | Replacement of GFC sensor's infra-red source (12.3.6)  | 2 years   |
| 7    | Replacement of SDA operator module (12.4.7)  | 7 years   |
| 8    | Replacement of base plate assembly (12.3.4)  | 7 years   |

**Table 12 On board maintenance tasks**

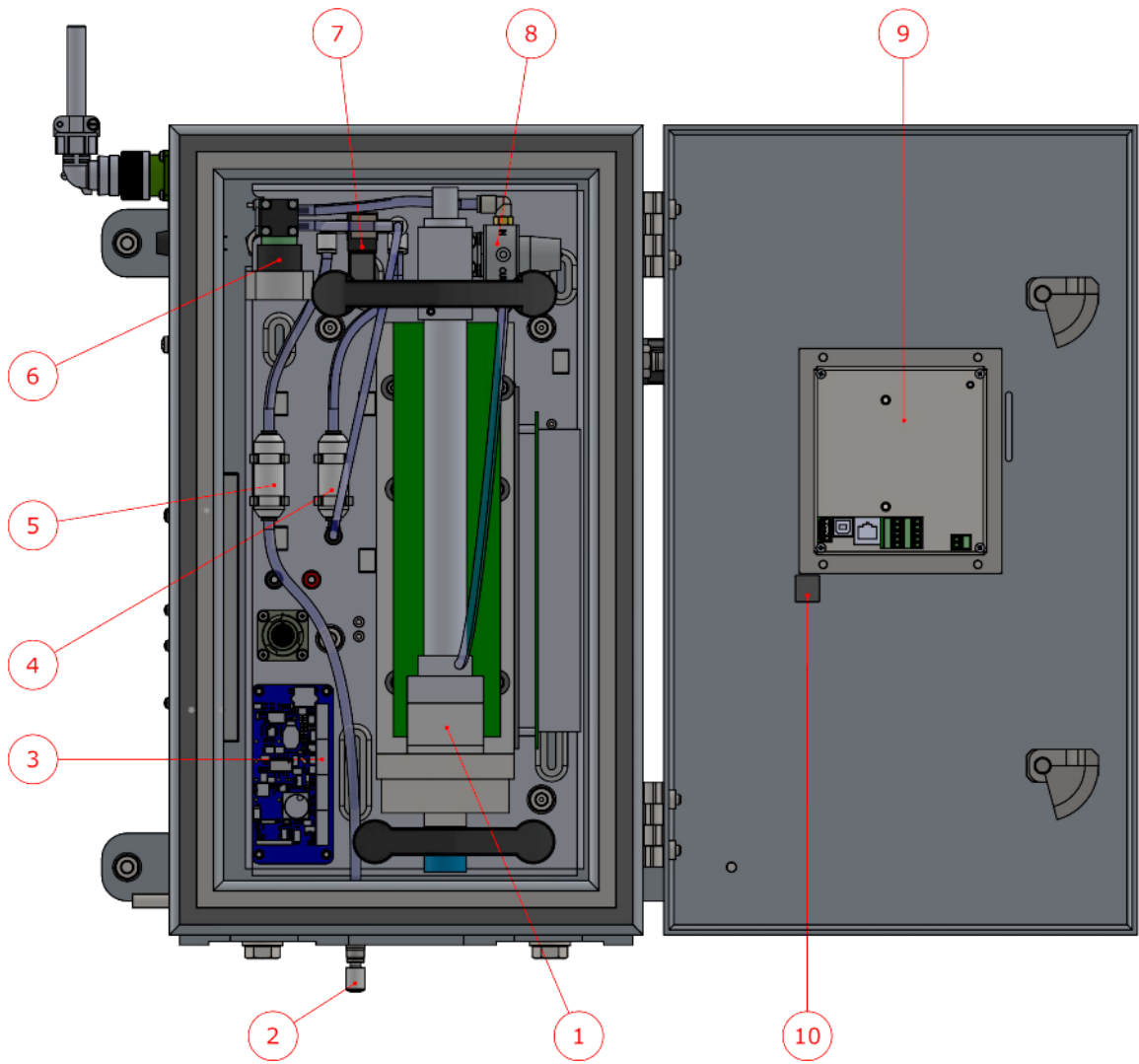
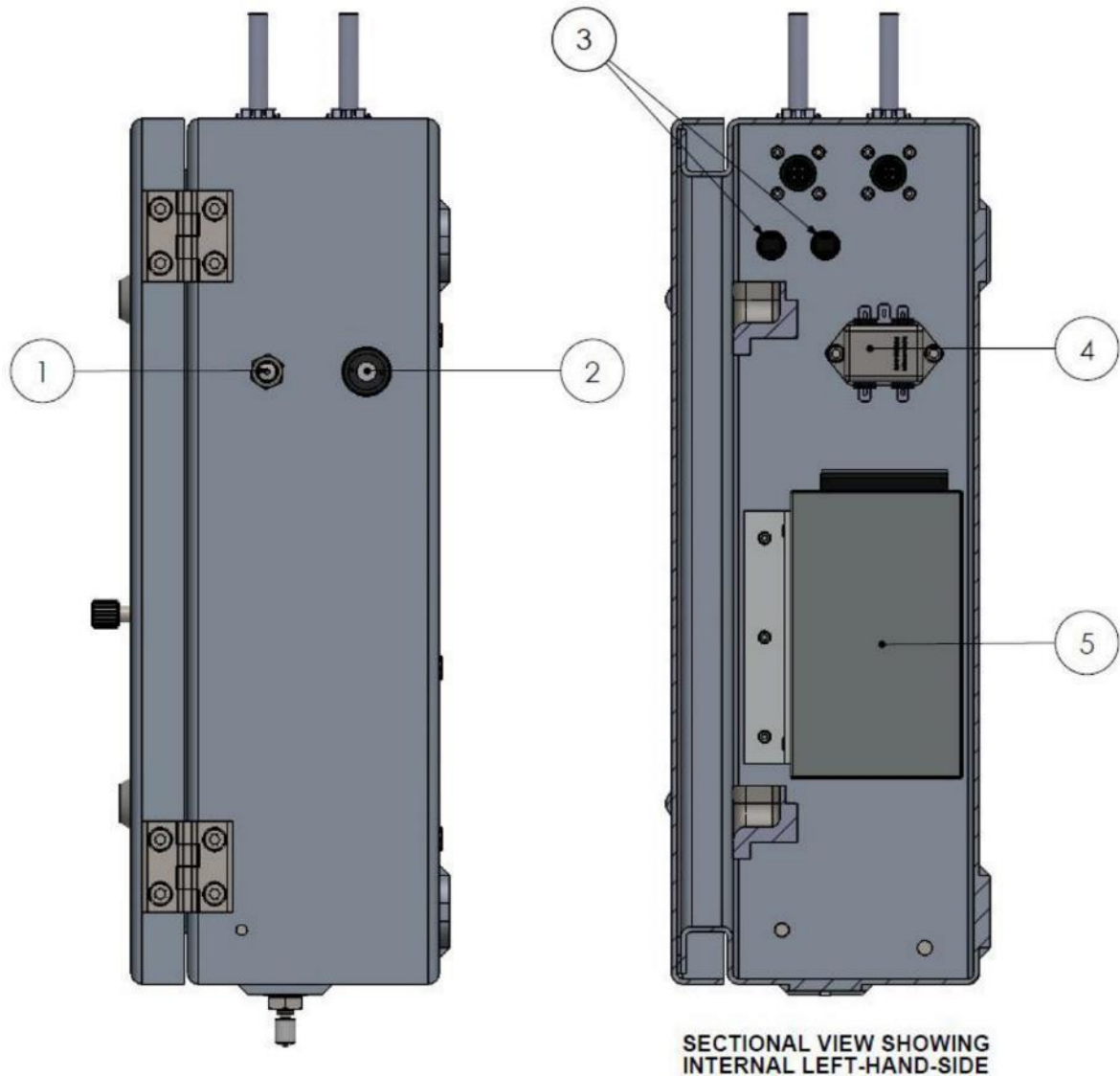

Figure 25 COSAMS internal components (1)

Key

- |   |                             |    |                      |
|---|-----------------------------|----|----------------------|
| 1 | GFC CO sensor               | 6  | Sample Pump          |
| 2 | Inlet pre-filter            | 7  | Solenoid valve       |
| 3 | COSAMS interface PCB        | 8  | Flow switch          |
| 4 | Auto-zero catalyst module   | 9  | SDA operator console |
| 5 | Internal particulate filter | 10 | Rotary encoder       |





**Figure 26** COSAMS internal components (2)

**Key**

- 1 Exhaust pre-filter
- 2 Breather port
- 3 Fuse holders (AC variant), fuse holders are located internally on DC variants
- 4 Power filter
- 5 Power supply unit (PSU)

**⚠ WARNING: DISCONNECT THE POWER SUPPLY BEFORE PERFORMING ANY MAINTENANCE WITHIN THE CABINET.**

### 12.3.1 Filter check and replacement

There are 3 filters requiring periodic replacement: the inlet and outlet pre-filters, which are identical and the internal particulate filter.

#### 12.3.1.1 Gas inlet and exhaust pre-filters

The pre-filters are push-fit fittings – remove by pushing the fitting's collar against the body of the fitting and withdrawing the pre-filter.



#### 12.3.1.2 Internal filter element replacement

The internal filter is a cartridge-type, mounted on the baseplate assembly within the COSAMS unit.

- 1] **Unclip the left most cartridge from its bracket by pulling it away from the baseplate.**
- 2] **Remove the tubing from the inlet (bottom) and tubing from the outlet (top) by pushing the collar of the fitting toward the body of the cartridge to release the grip on the elbow/tube.**
- 3] **Open the cartridge and remove the filter element by rotating the inlet end of the cartridge anticlockwise to the open ('O') position.**





- 4] Pull out the inlet fitting and remove the filter element.
- 5] Inspect the O-ring on the inlet fitting and if damaged in anyway, or showing signs of wear, the full filter housing including a new element is required to be replaced (See section 12.3.1.3).
- 6] Insert the new filter element, re-assemble the cartridge and re-install in the COSAMS.

#### 12.3.1.3 Replacing the filter housing (Inc. element)

The complete filter housing is supplied with a mounting bracket, the mounting bracket can be disposed of as this is already fitted to the baseplate.

If the oring is found to be damaged or showing signs of wear during the filter element change, the full filter housing inc. the element is required to be replaced.

- 1] Remove the pipework from each end of the filter housing.

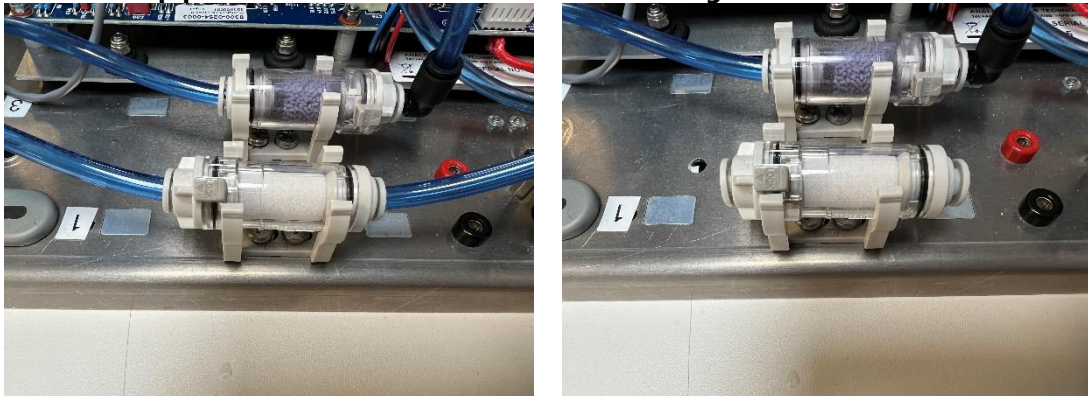

- 2] Pull the housing from its bracket.

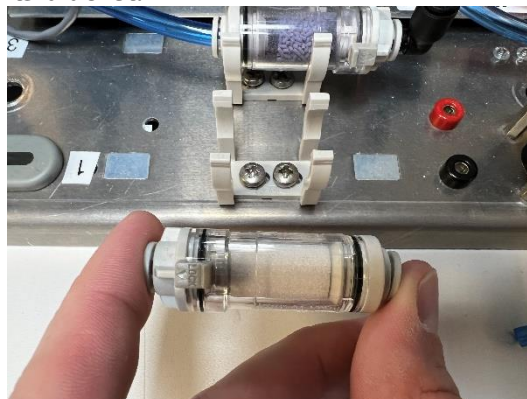

- 3] Reverse previous steps to install the new filter housing, observing orientation.

### **12.3.2 Auto-zero catalyst replacement**

The auto-zero catalyst is supplied in a filter canister; replacing the catalyst is simply a matter of swapping out the old canister for the new.

Follow steps [1] and [2] of the procedure for removing the internal particulate filter to remove the old catalyst.

If the catalyst is being replaced as a result of the COSAMS reporting a catalyst fault (*Sensor fault: CAT*):

- 1] Clear the fault by entering the SDA operator console main menu and select:  
*Replace catalyst... > CO sensor (1) > Yes***
- 2] Manually initiate an auto-zero once the COSAMS warm-up period has expired:  
*Auto-zero... > CO sensor (1)***

### **12.3.3 Cabinet breather inspection/replacement**

Inspect the cabinet's breather port, externally mounted on the right-hand side of the cabinet – if the central white, sintered section appears to be fouled then the breather should be replaced.



The breather may be removed from the cabinet by unscrewing the plastic nut on the rear. When installing a new breather, ensure that the O-ring is correctly seated in the groove on the back face of the breather.

### **12.3.4 Removal and replacement of the baseplate assembly**

It is necessary to remove the COSAMS baseplate assembly to service/replace some components and also to mount the cabinet on shock isolators.

#### **12.3.4.1 Baseplate assembly removal**

- 1] Disconnect the power input connector to isolate the COSAMS from the supply.**
- 2] Open the cabinet and disconnect the tubing at the gas inlet/exhaust ports.**



(The gas inlet/exhaust ports are shown in the photograph on the left, highlighted with arrows)

- 3] Unscrew the outer collar of the circular DC power connector 120° and unplug the connector.**



(The circular DC power connector is shown in the photograph on the left, highlighted with an arrow)

- 4] Unplug the SDA operator console power connector and the RS485 connections to the Interface PCB and Output Module PCB (marked *SENS* and *DATA*, respectively).**



(The SDA operator console connectors are shown in the photograph on the left, highlighted with an arrow)

- 5] Remove the four sets of M8 nuts/spring washers/flat washers that retain the baseplate.**



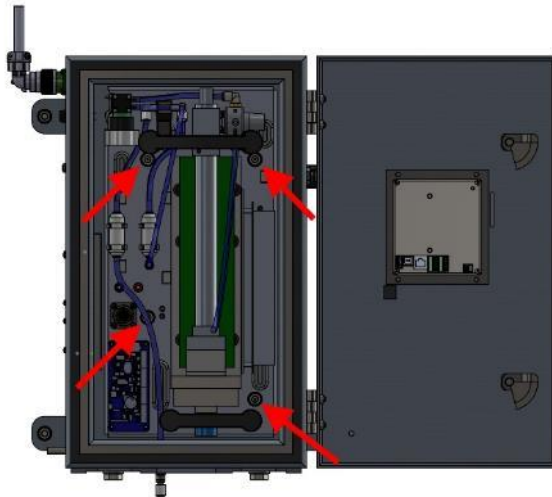

(The M8 retaining nuts and washers are shown in the drawing on the left, highlighted with arrows)

- 6] **Withdraw the baseplate assembly from the cabinet, taking particular care not to bump any parts of the GFC CO sensor.**

#### 12.3.4.2 Refitting the baseplate assembly

To refit the baseplate, ensure that the baseplate earth strap is located on the lower-left mounting stud and then follow the removal instructions, section 12.3.4.1, in reverse order.

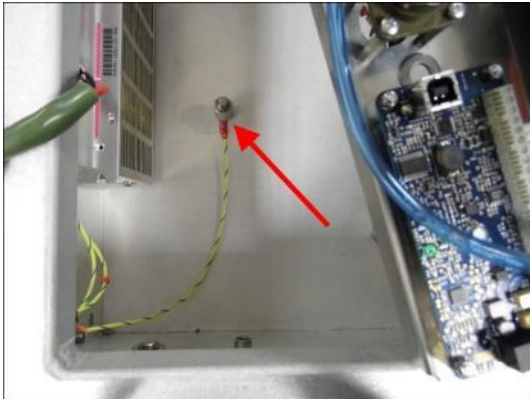

**CAUTION: ENSURE THE EARTH STRAP SITS ON THE MOUNTING STUD BEFORE REFITTING THE BASEPLATE.**

### 12.3.5 Sample pump replacement

Replacing the sample pump requires removal of the baseplate assembly, as described in section 12.3.4.  
With the baseplate removed:

- 7] **Disconnect the pump wiring from the terminal block (Wires 36 & 37) on the rear of the baseplate, remove the three white low smoke cable ties securing the pump wiring and feed through the oval grommet underneath the pump.**

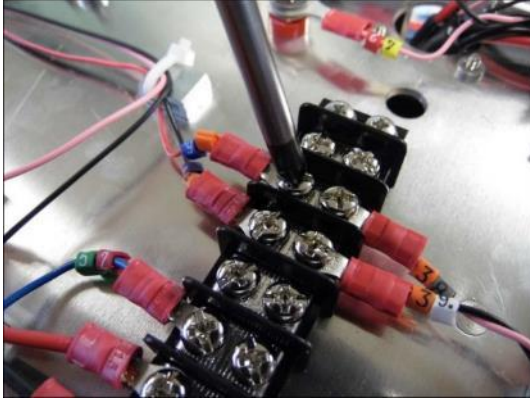

(The pump wiring terminal block is shown in the photograph on the left)

- 8] **Open the tube securing clips by pushing the clip open with a terminal driver to loosen the teeth, then remove the tubing from the inlet (Left spigot) and outlet (Right spigot).**

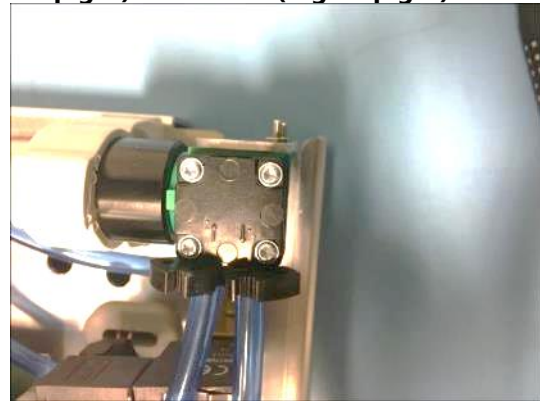
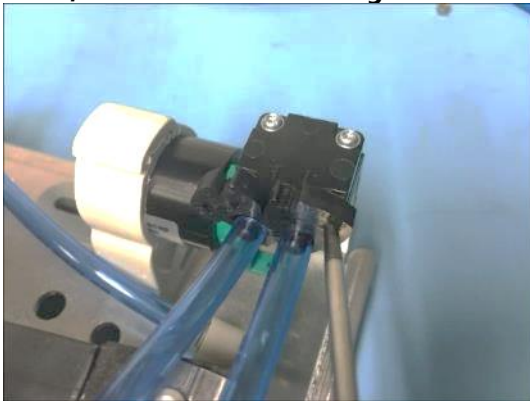

- 9] **Pop the mount clip open around the pump body.**

- 10] Remove the two M2.5 x 10mm Pozi Pan Screws, M2.5 spring washers and M2.5 flat washers from the inside face of the pump bracket on the upright using a long (200mm blade length) PZ1 screwdriver, access is via the gap above the flow switch and below the GFC sensor.

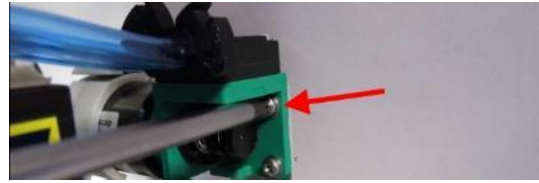



### **12.3.6 Infra-red source replacement**

Replacing the sensor's infra-red source, located at the bottom end of the CO sensor, requires removal of the baseplate assembly, as described in section 12.3.4. With the baseplate removed:

- 1] Disconnect the motor harness connector from the power PCB as shown, then disconnect the source harness from the screw terminal connector on the power PCB.**

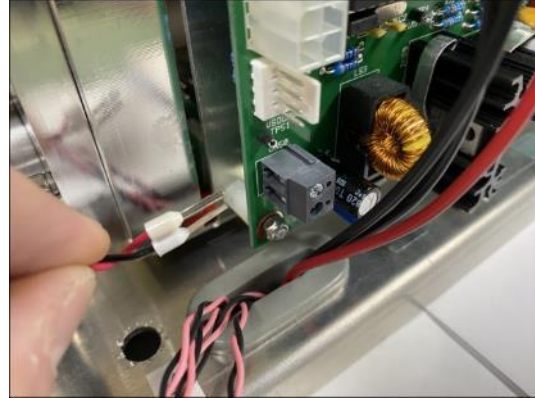
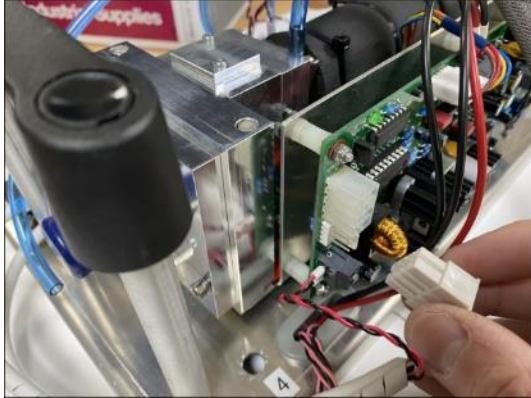

- 2] Unwrap the cable wrap from the motor harness as shown to release the connection end of the IR source harness.**

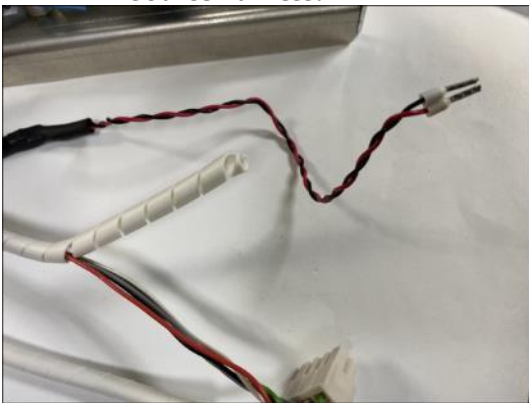

- 3] Remove the two bolts and washers securing the source to the motor plate (requires a 2mm hex key).**

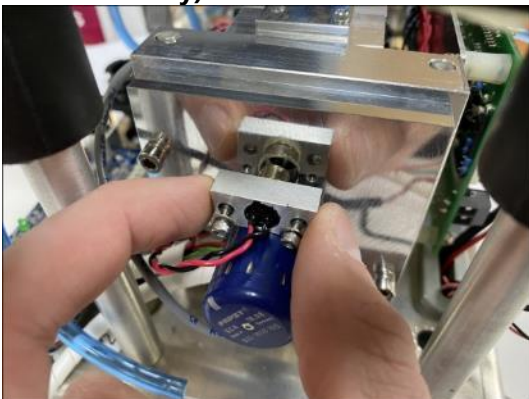

- 4] Unwrap the cable wrap from the motor harness as shown to release the source end of the IR source harness.

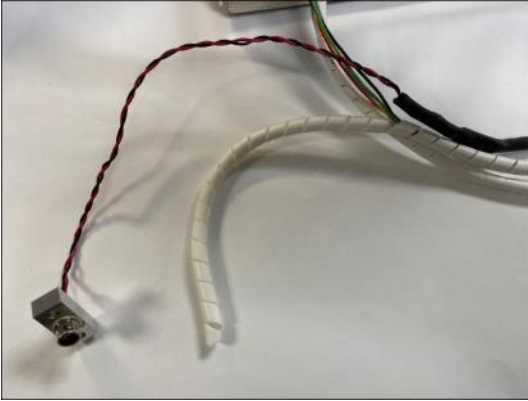

- 5] Fit the replacement IR source assembly and rewrap the cable wrap around the source end and the connection end of the harness as shown.

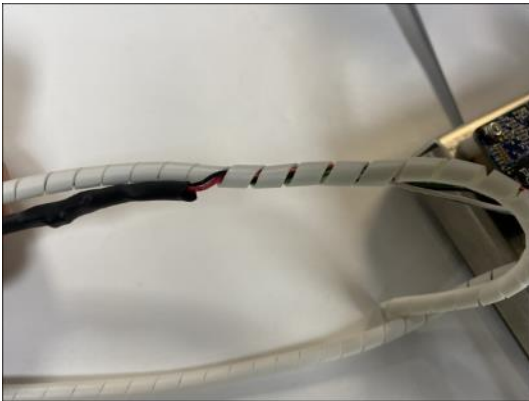

- 6] Refit the IR source block to the motor plate using the previously removed bolts and washers.



⚠ **CAUTION: THE SOURCE BOLT HOLES ARE OVER-SIZED ALLOWING A HIGH DEGREE OF POSITIONAL VARIABILITY. CARE MUST BE TAKEN TO ENSURE THAT THE SOURCE HOUSING DOES NOT TOUCH THE SENSOR'S MOTOR AS THIS WILL CAUSE THE SENSOR TO MALFUNCTION.**

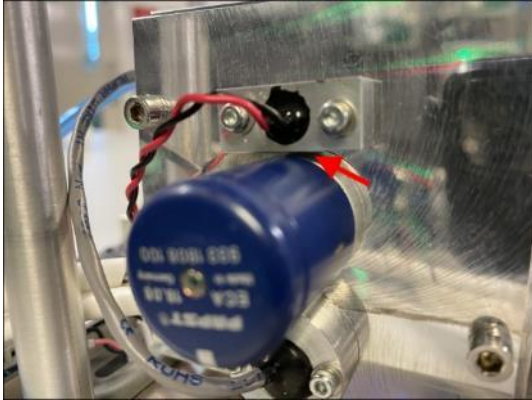

⚠ **CAUTION: THE SOURCE HOUSING  
MUST NOT FOUL ON THE MOTOR;  
MAINTAIN A GAP OF AT LEAST 0.5MM.**

- 7] Refit the IR source harness to the screw terminal connector on the power PCB, then Refit the motor harness connector to the power PCB.

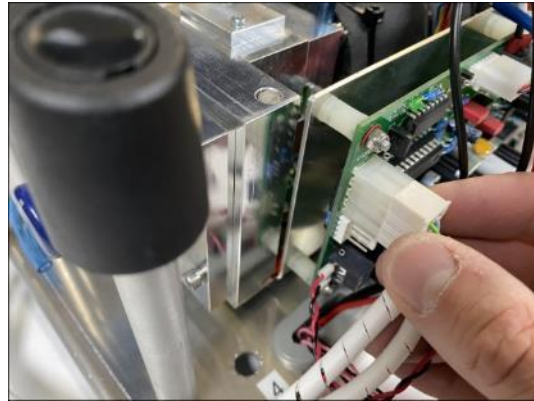
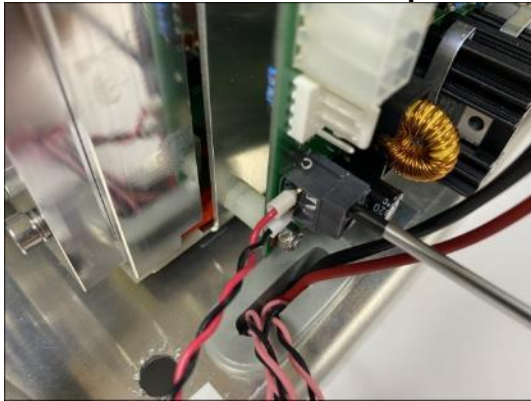

- 8] Once the COSAMS has been re-assembled, powered-up and the warm-up time has elapsed, calibrate the system (refer to section 12.4.8).



## 12.4 Non-periodic maintenance

The following tasks are not part of the routine periodic maintenance but are detailed to assist with repair of the COSAMS in the event of an unexpected component failure.

### 12.4.1 Solenoid valve replacement

Replacing the solenoid valve requires removal of the baseplate assembly, as described in section 12.3.4. With the baseplate removed:

- 1] **Disconnect the solenoid valve electrical connector by unscrewing it from the body of the solenoid valve.**
- 2] **Disconnect the pipework from the push-fit fittings, noting the relative positions for re-assembly.**

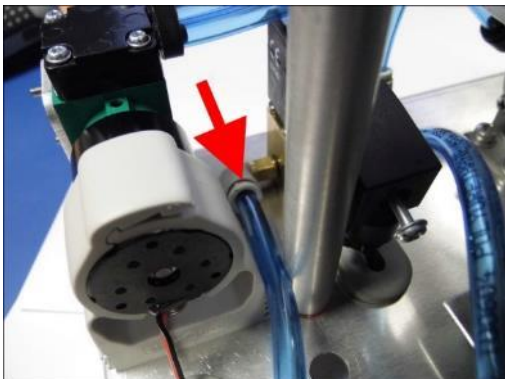
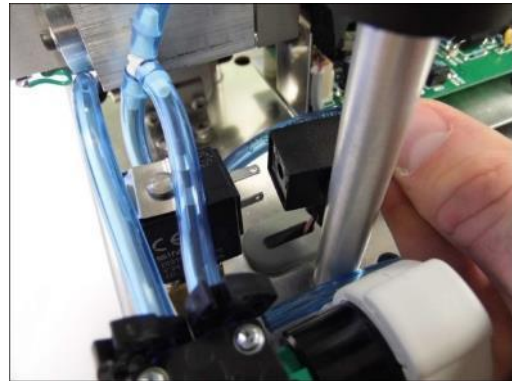
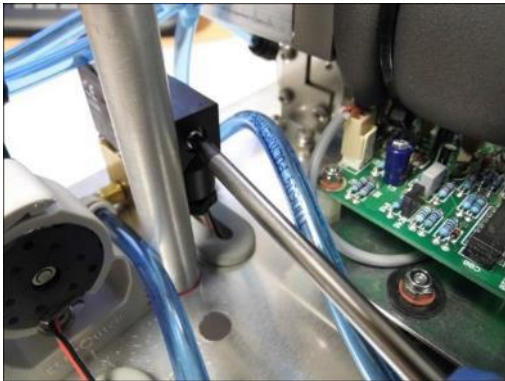

- 3] **Undo the M3 mounting hardware from the underside of the baseplate to remove the valve.**



- 4] **Recover the gas fittings from the base of the valve and install in the new valve.**
- 5] **Orientate the gas ports and then mount the new valve on the baseplate.**

**6] Refit the pipework and electrical connector.**

**12.4.2 Flow switch replacement**

Replacing the flow switch requires removal of the baseplate assembly, as described in section 12.3.4.  
With the baseplate removed:

- 1] Remove the three white low smoke cable ties securing the flow switch wiring and disconnect the flow switch wiring from the terminal rail on the underside of the baseplate (Blue wire – 52) & interface PCB on the front of the baseplate (40 & 41), remove the wiring by un-routing it on the underside of the baseplate and feed through the oval grommet under the flow sensor.**

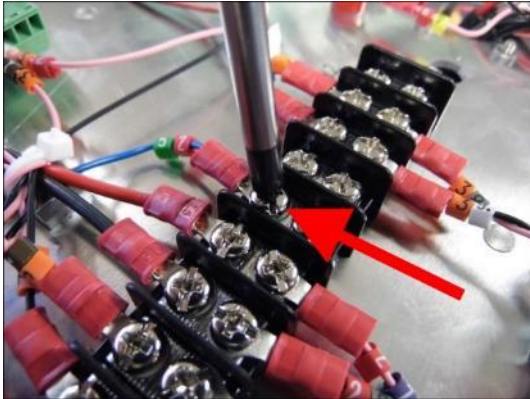

- 2] Disconnect the flow switch pipework from the push fit elbows (Pump to 'IN', 'OUT' to GFC sensor inlet) on the flow switch.**
- 3] Remove the M4 mounting hardware (Screw & Washer) to allow the flow switch to be removed from the baseplate.**

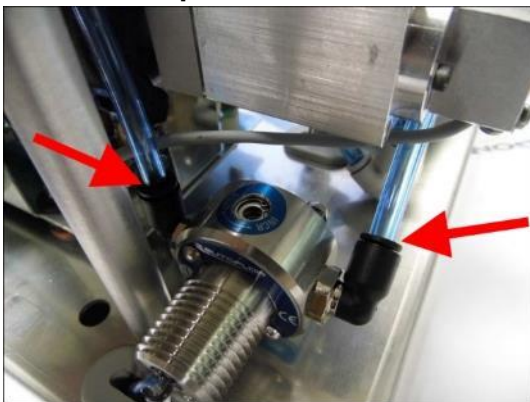

**Above: Flow switch pipework and mounting hardware**

**Reverse steps [3] – [1] to install the new flow switch.**

**12.4.3 Replacing the power supply unit (AC variant)**

Replacing the power supply unit (PSU) requires removal of the baseplate assembly, as described in section 12.3.4.

With the baseplate removed:

- 1] **Remove the 5 sets of M3 mounting hardware from the left-hand side of the cabinet – the two on the left are M3 x 8mm and screw directly in to the PSU itself, the three on the right are M3 x 16mm and hold the PSU supporting bracket to the cabinet.**

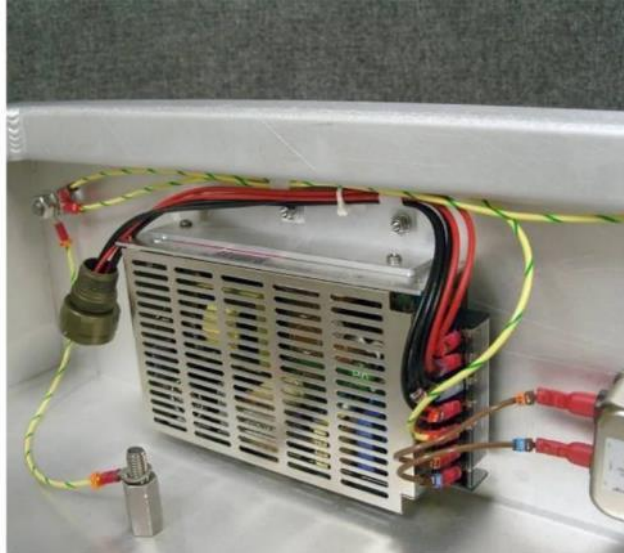

- 2] **Unclip the terminal cover and disconnect all of the wiring connections.**
- 3] **Withdraw the power supply, and recover the PSU supporting bracket and two mounting screws.**
- 4] **Fit the bracket to the new PSU – the screws should be treated with a suitable thread-locking compound, e.g., Loctite 222, or a shake-proof washer should be used to prevent loosening under vibration.**
- 5] **Wire up the new PSU as shown and fit the terminal cover:**

| PSU terminal | Wire number | Colour       |
|--------------|-------------|--------------|
| L            | 16          | Brown        |
| N            | 13          | Brown        |
| E            | 2           | Green/Yellow |
| V-           | 21          | Black        |
| V-           | 18,19       | Black        |
| V+           | 17          | Red          |
| V+           | 20          | Red          |

- 6] **Very loosely fasten the PSU to the cabinet using the two M3 x 8mm screws (again, use either thread-locking compound or a shake-proof washer) to allow alignment of the supporting bracket with its mounting holes. Fit the PSU supporting brackets M3 x 16mm screws with M3 flat washers from the outside of the cabinet and secure with the following hardware internally:**

| <b>Mounting screw</b> | <b>Internal fittings/fasteners (in order of fitting)</b>                  |
|-----------------------|---|
| Top                   | cable clamp (holds wires 17-21)<br>M4 washer<br>M3 washer<br>M3 nyloc nut |
| Middle                | cable clamp (holds wires 1 & 2)<br>M4 washer<br>M3 washer<br>M3 nyloc nut |
| Bottom                | M3 nyloc nut  |

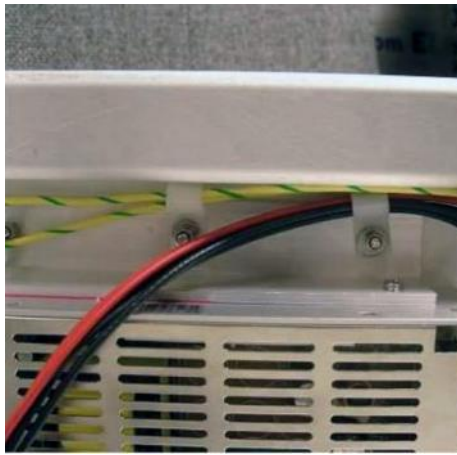

**7] Fully tighten all hardware.**



**12.4.4 Replacing the power supply unit (DC variant)**

Replacing the power supply unit (PSU) requires removal of the baseplate assembly, as described in section 12.3.4.

With the baseplate removed:

- 1] **Remove the 4 sets of M3 mounting hardware from the top left-hand side of the cabinet – they are all M3 x12 Pozi Pan screws with M3 flat washers on the external face, secured with M3 flat washers & M3 Nyloc nuts on the internal face.**

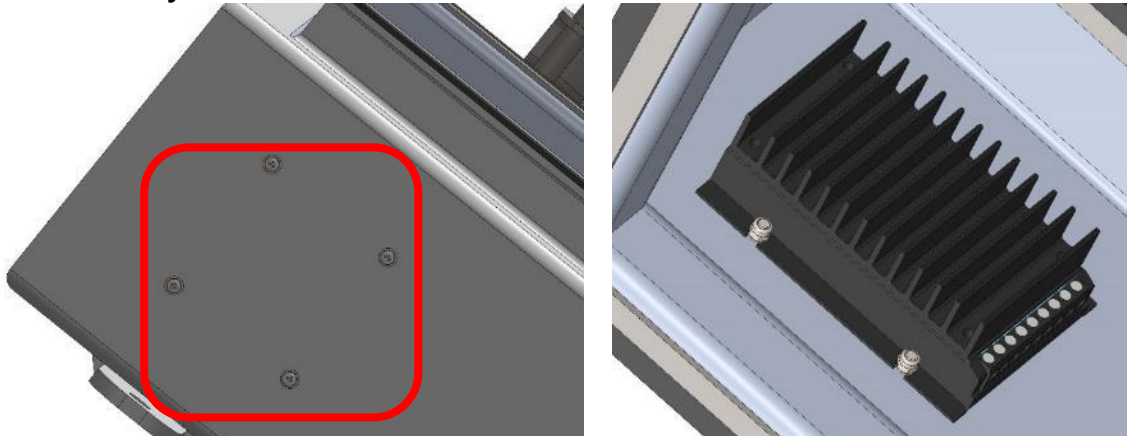

- 2] **Disconnect all of the wiring connections from the screw terminal block on the PSU.**
- 3] **Withdraw the power supply.**
- 4] **Wire up the new PSU as detailed below and fit the terminal cover:**

| PSU terminal No | Wire number | Colour |
|-----------------|-------------|--------|
| 1 +Vi           | NC          | NC     |
| 2 +Vi           | 13          | Red    |
| 3 -Vi           | NC          | NC     |
| 4 -Vi           | 16          | Black  |
| 5 Ctrl          | NC          | NC     |
| 6 +Vo           | 17 & 20     | Red    |
| 7 -Vo           | 18, 19 & 21 | Black  |
| 8 Trim1         | NC          | NC     |
| 9 Trim2         | NC          | NC     |

- 5] **Refit the PSU using the 4 sets of M3 mounting hardware from the left hand side of the cabinet – they are all M3 x12 Pozi Pan Screws with M3 flat washers on the external face, secured with M3 flat washers & M3 Nyloc nuts on the internal face, secure the PSU in place.**



### **12.4.5 Replacing the SDA Output Module PCB**

Replacing the SDA Output Module PCB requires removal of the baseplate assembly, as described in 12.3.4. With the baseplate removed:

- 1] With the baseplate upside down, unplug the electrical connections from the PCB.**

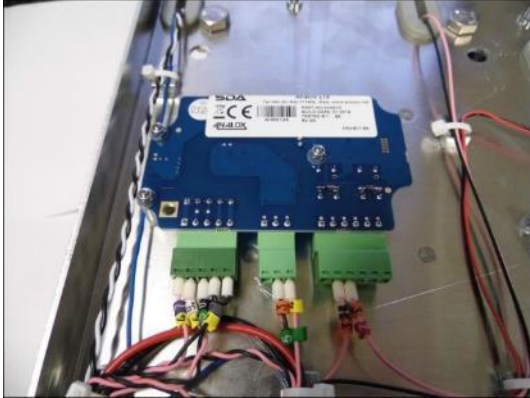

- 2] Remove the PCB by unscrewing the three M2.5 Nyloc nuts and nylon washers (This will also remove the insulating pillars underneath the PCB from the baseplate).**
- 3] Remove the insulated pillars from the PCB and refit to the baseplate.**



- 4] Refit the PCB to the pillars and secure with the M2.5 Nylon washers and Nyloc Nuts.**
- 5] Refit the electrical connectors.**

#### 12.4.6 Replacing SDA Operator Console membrane label

- 1] Loosen the grub screw (2mm hex key required) securing the rotary encoder knob and remove the knob from the encoder shaft.



- 2] Remove the 2 encoder retaining nuts and pass the encoder back through the panel.
- 3] Disconnect the ribbon cable, unfasten the shield tag and remove the adhesive (used to prevent chafing of the wiring) from the slot in the cabinet door.

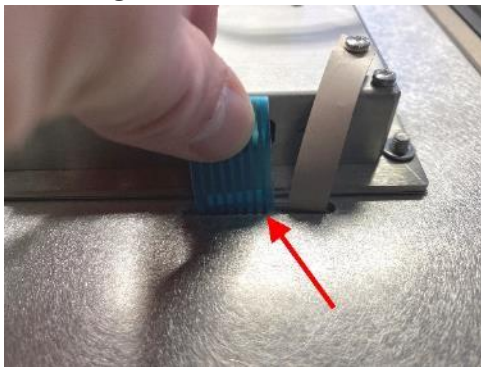

- 4] Peel the membrane from the cabinet door and clean any remnants of adhesive from the door.
- 5] Remove the protective film from the rear of the replacement label. Feed the ribbon cable and shield tag through the slot in the cabinet door, align the membrane with the LCD and encoder hole and affix the membrane to the door.
- 6] Connect the ribbon cable to the 7 way right angle header coming through the side of the SDA rear cover.

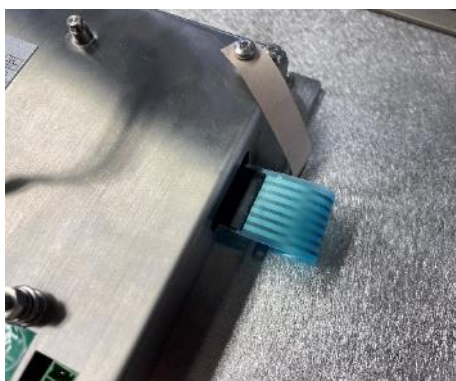

- 7] Cut a small slot in the shield tag and fit over the stud on the rear top-right corner of the SDA with one of the Nord lock washers above and one below.

- 8] Run a bead of glue/sealant, e.g., silicone sealant, along the cable slot to fix the ribbon cable and shield tag in place and prevent chafing against the edge of the slot.
- 9] Refit the rotary encoder and knob. Ensure that both nuts are used to mount the encoder, this prevents damage occurring to the device in the event of the knob being subject to an impact.

#### **12.4.7 Replacing the SDA Operator Console**

- 1] Disconnect the SDA electrical connections:
  - Unplug the ribbon cable connection to the membrane label and undo the shield tag from the SDA's upper earth stud.
  - Unplug the 5S3, output module and power connectors.
  - Disconnect the earth wire attached to the lower earth stud.
  - Carefully peel away the adhesive around the ribbon cable attached to the rotary encoder and unplug the encoder.
- 2] Undo the four nuts fastening the console to the mounting studs on the cabinet door and remove the console.
- 3] Mount the new SDA console on to the mounting studs, fit the nuts and washers and re-make all the electrical connections - Connect the ribbon cable to the 7 way right angle header coming through the side if the SDA rear cover.
- 4] Connect the shield tag and fit over the stud on the rear top-right corner of the SDA with one of the Nord lock washers above and one below.

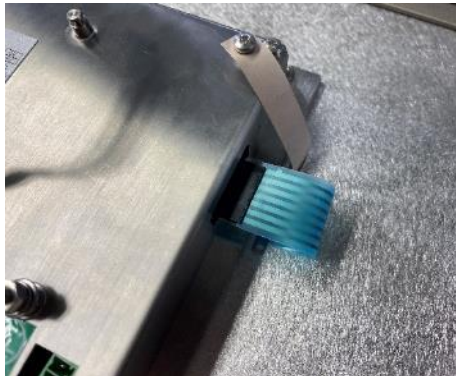

- 5] Apply a bead of adhesive, e.g., silicone sealant, to the encoder/ribbon cable connector joint to prevent accidental detachment.

### 12.4.8 CO sensor calibration

There are two methods of CO sensor calibration:

- a) 'Fine' calibration via the SDA operator console to maintain optimal performance as the sensor output drifts slightly as the sensor ages. This procedure is described in section 8.
- b) 'Coarse' calibration is required when sensor output drift has become significant; the GFC CO sensor's potentiometers must be adjusted to return the sensor's output to the nominal levels expected by the interface PCB. 'Coarse' calibration should always be followed by a 'fine' calibration.

The 'coarse' calibration procedure should be performed after servicing the COSAMS.

#### 12.4.8.1 'Coarse' calibration procedure

'Coarse' calibration is best performed on a fully warmed-up system.

**NOTE:** THE CO SENSOR IS SENSITIVE TO CHANGES IN TEMPERATURE; FOR BEST RESULTS, TRY TO MINIMISE THE PERIODS WHEN THE ENCLOSURE DOOR IS OPEN TO MAKE ADJUSTMENTS.

- 1] Connect a DVM (Digital Volt Meter) set to Volts dc to the red (+VE) & black (-VE) test points located next to the ITT Cannon 7 way panel connector on the baseplate using 4mm unshrouded test leads.

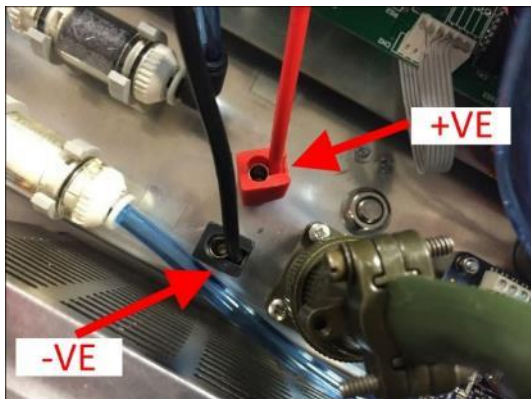

- 2] Remove central portion of lagging to gain access to the zero & span potentiometers:

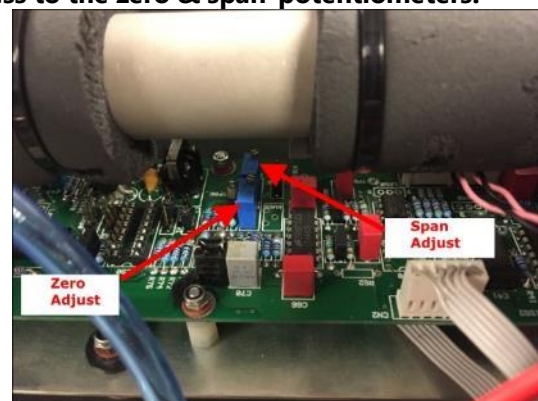

- 3] Apply zero gas to the sensor, as described in the fine calibration procedure (section 8).
- 4] Leave the gas to flow for approximately 3 minutes and then measure the CO sensor output signal using the DVM across test points (Red +VE) and (Black -VE) on the baseplate.



- 5] Adjust the GFC's zero potentiometer using a trimming tool, located beneath the optical bench, to achieve a sensor output voltage of  $0.8 \pm 0.05V$ .

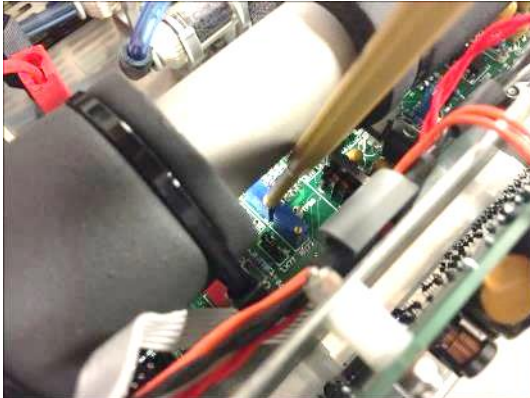

- 6] Swap to span gas (Recommended at 150ppm CO in air), as described in the fine calibration procedure (section 8).

- 7] Adjust the span potentiometer using a trimming tool to achieve a sensor output voltage of  $2.225 \pm 0.05 V$  dc, this is dependent on using a 150ppm CO in air span gas. If using a 200ppm CO in air span gas the output would be  $\sim 2.7 \pm 0.05 V$  dc.



- 8] Repeat steps [2] through [6] until no further adjustment of the potentiometers is required.

- 9] **Replace central portion of lagging.**

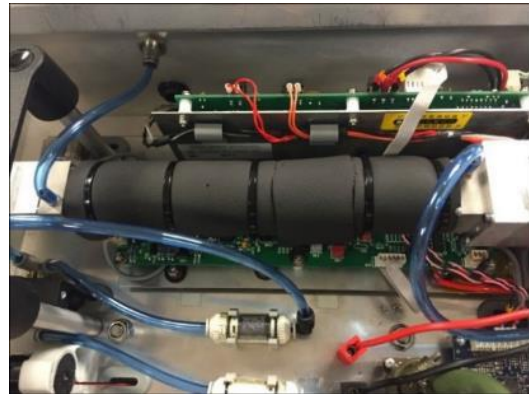
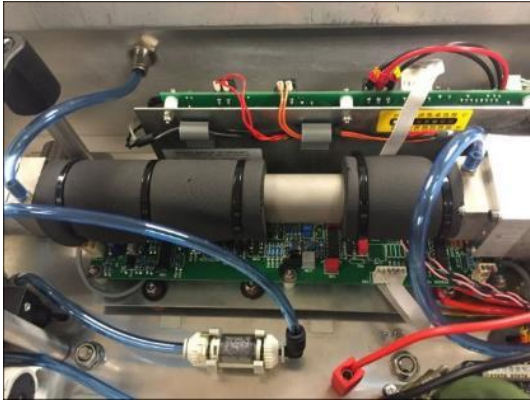

- 10] **Remove the test leads from the test points on the baseplate and shut the cabinet door.**  
11] **Allow the system temperature to stabilise for approximately 20 minutes and then perform a fine calibration, according to section 8.**

**13      Warranty**

TBD

## 14 Fault reporting to Analox

In the event of a fault arising, the following table may be of use when reporting the fault to Analox. Please complete whichever sections are believed to be relevant to the fault and return a copy to Analox - contact details can be found on the front page of this manual.

|             |  |
|-------------|--|
| <b>Date</b> |  |
|-------------|--|

|                                 |  |
|---------------------------------|--|
| <b>Company/institution name</b> |  |
| <b>Customer contact</b>         |  |
| <b>Address</b>                  |  |
| <b>Country</b>                  |  |
| <b>Telephone number</b>         |  |
| <b>Mobile telephone number</b>  |  |
| <b>Email address</b>            |  |

|                                 |  |
|---------------------------------|--|
| <b>COSAMS serial no.</b>        |  |
| <b>CO sensor serial no.</b>     |  |
| <b>SDA console serial no.</b>   |  |
| <b>System Operating Voltage</b> |  |
| <b>Description of fault</b>     |  |
|                                 |  |



## 15 Specifications

### 15.1 Mechanical specifications

|   |                 |
|---|-----------------|
| <b>Nominal cabinet dimensions (mm):<br/>h x w x d, exc. mounting lugs</b> | 479 x 280 x 175 |
| <b>Nominal system dimensions (mm):<br/>h x w x d</b>                      | 600 x 360 x 200 |
| <b>Weight (kg)</b>  | 11              |
| <b>Cabinet material</b>   | Aluminium       |

### 15.2 Electrical specifications (AC variant)

|                               |                       |
|-------------------------------|-----------------------|
| <b>Electrical supply</b>      | 115V AC 60Hz          |
| <b>Max. power consumption</b> | 90W                   |
| <b>Fuse rating (F1, F2)</b>   | 20mm, 2.5A anti-surge |
| <b>Signal output</b>          | 4-20mA                |
| <b>EMC compliance</b>         | MIL-STD-461F          |
| <b>ESD compliance</b>         | EN 61000-4-2          |

### 15.3 Electrical specifications (DC variant)

|                               |  |
|-------------------------------|--|
| <b>Electrical supply</b>      | 24V DC   |
| <b>Max. power consumption</b> | 55W (During warmup)<br>40W (During normal operation) |
| <b>Fuse rating (F1, F2)</b>   | 38x10mm, 16A anti-surge                              |
| <b>Signal output</b>          | 4-20mA   |
| <b>EMC compliance</b>         | MIL-STD-461F   |
| <b>ESD compliance</b>         | EN 61000-4-2   |

**15.4 Environmental specifications**

|  |   |
|--|---|
| <b>Operating temperature range</b>             | 0 to +45°C  |
| <b>Storage temperature</b>                     | -40 to +70°C  |
| <b>Operating pressure range</b>                | 700 to 1300 hPa   |
| <b>Extended pressure range<sup>1</sup></b>     | 600 to 700 hPa  |
| <b>Storage/transport pressure range</b>        | 300 to 1400 hPa   |
| <b>Operating humidity range</b>                | 0 to 80 %RH   |
| <b>Extended humidity range (up to 1 hr)</b>    | 80 to 100 %RH   |
| <b>Storage humidity range</b>                  | 0 to 80 %RH (temporary max. 100 %RH)                    |
| <b>Max. roll angle (constant)<sup>2</sup></b>  | 15°   |
| <b>Max. roll angle (temporary)</b>             | 45°   |
| <b>Max. pitch angle (constant)<sup>2</sup></b> | 10°   |
| <b>Max. pitch angle (temporary)</b>            | 30°   |
| <b>Shock</b>                                   | Tested at 22g, 20ms (half sine) without shock isolation |
| <b>Vibration</b>                               | NATO STANAG 4138  |

<sup>1</sup> Degraded performance is permissible over the pressure range 600-800hPa.

<sup>2</sup> The system shall operate at any legal combination of roll & pitch angles and continue to satisfy the specified accuracy requirement.

**15.5 Performance specifications**

|  |   |
|--|---|
| <b>CO measuring range</b>                                      | 0 – 200 ppm                             |
| <b>Repeatability, measured at RTP</b>                          | ± (1 ppm CO + 1 display count)          |
| <b>Accuracy across normal operating environmental envelope</b> | ±5% full scale (equivalent to ± 10 ppm) |
| <b>Zero drift</b>  | ±1 ppm CO / day                         |
| <b>Cross-sensitivity to hydrogen</b>                           | 2 %vol H2 < 1ppm CO                     |
| <b>Cross sensitivity to carbon dioxide</b>                     | 5%vol CO2 < 1ppm CO                     |
| <b>Response time</b>   | T <sub>90</sub> < 60s                   |

## **16 Disposal**

### **16.1 WEEE statement**



According to WEEE regulation this electronic product cannot be placed in household waste bins. Please check local regulations for information on the disposal of electronic products in your area. Analox will provide a disposal service if this is beneficial to the customer. Analox are registered for the disposal of WEEE in the UK through the Environment Agency (2013 Registration number WEE/KE0043SY).

### **16.2 Catalyst disposal**

Dispose of contents/container in accordance with applicable local regulations.

## Appendix A PremiOx Gold safety datasheet

MATERIAL SAFETY DATASHEET. Premier Chemicals Ltd



### SECTION 1: PRODUCT AND COMPANY IDENTIFICATION

**PRODUCT NAME:** PremiOx Gold Catalyst - Gold nanoclusters supported on Titanium Dioxide

**SUPPLIER:** Premier Chemicals Ltd

**ADDRESS:** PO Box 583

Huntingdon, PE29 9EF

United Kingdom

**Product Use:** Oxidation catalyst

**Emergency Contact Number:** + 44 1480 878134

### SECTION 2: INGREDIENTS

| <b>Ingredient</b> | <b>% by Wt</b> |
|-------------------|----------------|
| Titanium oxide    | > 95%          |
| Gold nanoclusters | <5 %           |

### SECTION 3: HAZARDS IDENTIFICATION

#### 3.1 EMERGENCY OVERVIEW

**Specific physical form:** Pellets

**Odour, Colour:** Odourless, Purple

**General Physical Form:** Solid

#### 3.2 POTENTIAL HEALTH EFFECTS

**Eye contact:**

Mechanical eye irritation: Signs / symptoms may include pain, redness, tearing and corneal abrasion.

**Skin contact:**

Mechanical skin irritation: Signs / symptoms may include redness, abrasion, pain and itching.

**Inhalation:**

Respiratory Tract Irritation: Signs / symptoms may include cough, sneezing, nasal discharge, headache, and nose and throat pain.

**Ingestion:**

No health effects are expected.

**Classification of the substance or mixture**

Not a hazardous substance or mixture according to Regulation (EC) No.1272/2008.

This substance is not classified as dangerous according to Directive 67/548/EEC.

MATERIAL SAFETY DATASHEET. Premier Chemicals Ltd

---

**SECTION 4: FIRST AID MEASURES**

**4.1 DESCRIPTION OF FIRST AID MEASURES**

**In case of eye contact:**

Flush eyes with water as a precaution.

**In case of skin contact:**

Wash off with soap and plenty of water.

**If inhaled:**

If breathed in, move person into fresh air. If not breathing, give artificial respiration.

**If Swallowed:**

Never give anything by mouth to an unconscious person. Rinse mouth with water.

**SECTION 5: FIRE FIGHTING MEASURES**

**5.1 FLAMMABLE PROPERTIES:**

|                           |                |
|---------------------------|----------------|
| Auto-ignition temperature | >800°C         |
| Flash point               | Not applicable |
| Flammable Limits - LEL    | Not applicable |
| Flammable Limits – UEL    | Not applicable |

**5.2 EXTINGUISHING MEDIA**

Use fire extinguishers with class B extinguishing agents (e.g., dry chemical, carbon dioxide)

**SECTION 6: ACCIDENTAL RELEASE MEASURES**

**6.1 PERSONAL PRECAUTIONS, PROTECTIVE EQUIPEMNT AND EMERGENCY PROCEDURES**

Avoid dust formation. Avoid breathing vapours, mist or gas. For personal protection see section 8.

**6.2 ENVIRONMENTAL PRECAUTIONS**

Do not let product enter drains.

**6.3 METHODS AND MATERIALS FOR CONTAINMENT AND CLEANING UP**

Sweep up and shovel. Keep in suitable, closed containers for disposal.

**SECTION 7: HANDLING AND STORAGE**

**7.1 PRECAUTIONS FOR SAFE HANDLING**

Provide appropriate exhaust ventilation at places where dust is formed. If ventilation is not adequate, use respiratory protection equipment.

MATERIAL SAFETY DATASHEET. Premier Chemicals Ltd

---

## 7.2 CONDITIONS FOR SAFE STORAGE, INCLUDING ANY INCOMPATIBILITIES

Store in cool, dry place and away from oxidizing agents. Keep container tightly closed in a dry and well-ventilated place.

### SECTION 8: PERSONAL PROTECTION

#### 8.1 PERSONAL PROTECTIVE EQUIPMENT (PPE)

##### 8.1.1 Eye/Face protection

The following eye protection(s) are recommended: **Safety glasses with side shields.**

##### 8.1.2 Skin protection

Handle with gloves. Dispose of contaminated gloves after use in accordance with applicable laws and good laboratory practices. Wash and dry hands.

##### 8.1.3 Body protection

The type of protective equipment must be selected according to the concentration and amount of the dangerous substance and the specific workplace.

##### 8.1.4 Respiratory protection

Use dust / particulate masks.

### SECTION 9: PHYSICAL AND CHEMICAL PROPERTIES

|                            |                   |
|----------------------------|-------------------|
| Specific, physical form:   | Powder, granule   |
| Odor, color:               | Odorless, grey    |
| General Physical form:     | Solid             |
| Auto-ignition temperature: | > 400°C           |
| Flash point                | Not applicable    |
| Flammable Limits - LEL     | Not applicable    |
| Flammable Limits – UEL     | Not applicable    |
| Density                    | No data available |
| pH                         | No data available |
| Solubility in water        | Insoluble         |

### SECTION 10: STABILITY AND REACTIVITY

#### 10.1 Reactivity

No data available.

#### 10.2 Chemical stability

Stable under recommended storage conditions.

#### 10.3 Possibility of hazardous reactions

No data available.

**MATERIAL SAFETY DATASHEET. Premier Chemicals Ltd**

---

**10.4 Conditions to avoid**

No data available.

**10.5 Incompatible materials**

Strong oxidizing materials.

**10.6 Hazardous decomposition products**

Other decomposition products -No data available.

In the event of fire: See section 5.

**SECTION 11: TOXICOLOGICAL INFORMATION**

**11.1 Information on toxicological effects**

Please contact the address listed on the first page of the MSDS for Toxicological information on this material and/or its components.

**SECTION 12: ECOLOGICAL INFORMATION**

**ECOTOXICOLOGICAL INFORMATION:** Not determined.

**CHEMICAL FATE INFORMATION:** Not determined.

**SECTION 13: DISPOSAL CONSIDERATIONS**

**DISPOSAL METHOD:**

Contact special disposal companies. Dispose of in accordance with Local Authority requirements. Recover and reclaim or recycle, if practical.

**SECTION 14: TRANSPORT**

**General:** Not classified as dangerous for transport

**UN No.** 0

|                       |  |
|-----------------------|--|
| Road transport notes: | Not classified as dangerous for road transport |
| Rail transport notes: | Not classified as dangerous for rail transport |
| Sea transport notes:  | Not classified as dangerous for sea transport  |
| Air transport notes : | Not classified as dangerous for air transport  |

**SECTION 15: REGULATORY INFORMATION**

In accordance with local and national regulations.

MATERIAL SAFETY DATASHEET. Premier Chemicals Ltd

---

**SECTION 16: OTHER INFORMATION**

**DISCLAIMER**

THE ABOVE INFORMATION IS BELIEVED TO BE CORRECT BUT DOES NOT PROPOSE TO BE ALL INCLUSIVE AND SHALL BE USED ONLY AS A GUIDE. PREMIER CHEMICALS SHALL NOT BE HELD LIABLE FOR ANY DAMAGE RESULTING FROM HANDLING OR CONTACT WITH THE ABOVE PRODUCT. THIS INFORMATION RELATES ONLY TO THE SPECIFIC MATERIAL DESIGNATED AND MAY NOT BE VALID FOR SUCH MATERIAL USED IN COMBINATION WITH ANY OTHER MATERIALS OR ANY PROCESS. IT IS THE USER'S RESPONSIBILITY TO SATISFY HIMSELF AS TO THE SUITABILITY OF SUCH INFORMATION FOR HIS OWN PARTICULAR USE.

IN NO WAY SHALL PREMIER CHEMICALS BE LIABLE FOR ANY CLAIM, LOSSES OR DAMAGES OF ANY THIRD PARTY OR FOR THE LOST PROFITS OR ANY SPECIAL, INDIRECT, INCIDENTAL, CONSEQUENTIAL OR EXEMPLARY DAMAGES, HOWSOEVER ARISING, EVEN IF THE COMPANY HAS BEEN ADVISED OF THE POSSIBILITY OF SUCH DAMAGES.



## Appendix B Nanaucat safety data sheet

3M Gold Catalyst AUC-16-1 05/12/14



### Safety Data Sheet

Copyright,2014,3M Company.

All rights reserved. Copying and/or downloading of this information for the purpose of properly utilizing 3M products is allowed provided that: (1) the information is copied in full with no changes unless prior written agreement is obtained from 3M, and (2) neither the copy nor the original is resold or otherwise distributed with the intention of earning a profit thereon.

|                        |           |                         |          |
|------------------------|-----------|-------------------------|----------|
| <b>Document Group:</b> | 26-4485-4 | <b>Version Number:</b>  | 3.00     |
| <b>Issue Date:</b>     | 05/12/14  | <b>Supersedes Date:</b> | 08/03/10 |

#### SECTION 1: Identification

##### 1.1. Product identifier

3M Gold Catalyst AUC-16-1

##### Product Identification Numbers

70-0715-3439-3

##### 1.2. Recommended use and restrictions on use

##### Recommended use

Catalyst

##### 1.3. Supplier's details

|                      |   |
|----------------------|---|
| <b>MANUFACTURER:</b> | 3M                                      |
| <b>DIVISION:</b>     | Personal Safety Division                |
| <b>ADDRESS:</b>      | 3M Center, St. Paul, MN 55144-1000, USA |
| <b>Telephone:</b>    | 1-888-3M HELPS (1-888-364-3577)         |

##### 1.4. Emergency telephone number

1-800-364-3577 or (651) 737-6501 (24 hours)

#### SECTION 2: Hazard identification

##### 2.1. Hazard classification

Carcinogenicity: Category 2.

##### 2.2. Label elements

##### Signal word

Warning

##### Symbols

Health Hazard |

##### Pictograms

3M Gold Catalyst AUC-16-1 05/12/14



**Hazard Statements**

Suspected of causing cancer.

**Precautionary Statements**

**Prevention:**

Obtain special instructions before use.  
Do not handle until all safety precautions have been read and understood.  
Wear protective gloves.

**Response:**

IF exposed or concerned: Get medical advice/attention.

**Storage:**

Store locked up.

**Disposal:**

Dispose of contents/container in accordance with applicable local/regional/national/international regulations.

**2.3. Hazards not otherwise classified**

None.

1% of the mixture consists of ingredients of unknown acute oral toxicity.

**SECTION 3: Composition/information on ingredients**

| Ingredient               | C.A.S. No. | % by Wt                 |
|--------------------------|------------|-------------------------|
| ACTIVATED CARBON         | 7440-44-0  | 80 - 100 Trade Secret * |
| ANATASE TITANIUM DIOXIDE | 1317-70-0  | 5 - 20 Trade Secret *   |
| GOLD                     | 7440-57-5  | < 1 Trade Secret *      |

\*The specific chemical identity and/or exact percentage (concentration) of this composition has been withheld as a trade secret.

**SECTION 4: First aid measures**

**4.1. Description of first aid measures**

**Inhalation:**

Remove person to fresh air. If you feel unwell, get medical attention.

**Skin Contact:**

Wash with soap and water. If signs/symptoms develop, get medical attention.

**Eye Contact:**

Flush with large amounts of water. Remove contact lenses if easy to do. Continue rinsing. If signs/symptoms persist, get medical attention.

3M Gold Catalyst AUC-16-1 05/12/14

**If Swallowed:**

Rinse mouth. If you feel unwell, get medical attention.

**4.2. Most important symptoms and effects, both acute and delayed**

See Section 11.1. Information on toxicological effects.

**4.3. Indication of any immediate medical attention and special treatment required**

Not applicable

**SECTION 5: Fire-fighting measures**

**5.1. Suitable extinguishing media**

In case of fire: Use a fire fighting agent suitable for ordinary combustible material such as water or foam to extinguish.

**5.2. Special hazards arising from the substance or mixture**

None inherent in this product.

**Hazardous Decomposition or By-Products**

| <u>Substance</u> | <u>Condition</u>  |
|------------------|-------------------|
| Carbon monoxide  | During Combustion |
| Carbon dioxide   | During Combustion |

**5.3. Special protective actions for fire-fighters**

No unusual fire or explosion hazards are anticipated.

**SECTION 6: Accidental release measures**

**6.1. Personal precautions, protective equipment and emergency procedures**

Evacuate area. Ventilate the area with fresh air. For large spill, or spills in confined spaces, provide mechanical ventilation to disperse or exhaust vapors, in accordance with good industrial hygiene practice. Warning! A motor could be an ignition source and could cause flammable gases or vapors in the spill area to burn or explode. Refer to other sections of this SDS for information regarding physical and health hazards, respiratory protection, ventilation, and personal protective equipment.

**6.2. Environmental precautions**

Avoid release to the environment.

**6.3. Methods and material for containment and cleaning up**

Collect as much of the spilled material as possible. Use wet sweeping compound or water to avoid dusting. Sweep up. Place in a closed container approved for transportation by appropriate authorities. Clean up residue. Seal the container. Dispose of collected material as soon as possible.

**SECTION 7: Handling and storage**

**7.1. Precautions for safe handling**

For industrial or professional use only. Do not handle until all safety precautions have been read and understood. Avoid breathing dust/fume/gas/mist/vapors/spray. Do not get in eyes, on skin, or on clothing. Do not eat, drink or smoke when using this product. Wash thoroughly after handling. Avoid contact with oxidizing agents (eg. chlorine, chromic acid etc.) Use personal protective equipment (gloves, respirators, etc.) as required.

**7.2. Conditions for safe storage including any incompatibilities**

Store away from oxidizing agents.

**SECTION 8: Exposure controls/personal protection**

3M Gold Catalyst AUC-16-1 05/12/14

**8.1. Control parameters**

**Occupational exposure limits**

| <b>Ingredient</b>  | <b>C.A.S. No.</b> | <b>Agency</b>                        | <b>Limit type</b>  | <b>Additional Comments</b> |
|--------------------|-------------------|--------------------------------------|--|----------------------------|
| ACTIVATED CARBON   | 7440-44-0         | Chemical<br>Manufacturer<br>Rec Guid | TWA:3 fiber/cc   |                            |
| Graphite           | 7440-44-0         | Amer Conf of<br>Gov. Indust.<br>Hyg. | TWA(respirable fraction):2<br>mg/m3                                |                            |
| Graphite           | 7440-44-0         | US Dept of<br>Labor - OSHA           | TWA:15 millions of<br>particles/cu. ft.                            |                            |
| GRAPHITE SYNTHETIC | 7440-44-0         | US Dept of<br>Labor - OSHA           | TWA(as total dust):15<br>mg/m3;TWA(respirable<br>fraction):5 mg/m3 |                            |

Amer Conf of Gov. Indust. Hyg. : American Conference of Governmental Industrial Hygienists  
 American Indust. Hygiene Assoc : American Industrial Hygiene Association  
 Chemical Manufacturer Rec Guid : Chemical Manufacturer's Recommended Guidelines  
 US Dept of Labor - OSHA : United States Department of Labor - Occupational Safety and Health Administration  
 TWA: Time-Weighted-Average  
 STEL: Short Term Exposure Limit  
 CEIL: Ceiling

**8.2. Exposure controls**

**8.2.1. Engineering controls**

Use general dilution ventilation and/or local exhaust ventilation to control airborne exposures to below relevant Exposure Limits and/or control dust/fume/gas/mist/vapors/spray. If ventilation is not adequate, use respiratory protection equipment.

**8.2.2. Personal protective equipment (PPE)**

**Eye/face protection**

Select and use eye/face protection to prevent contact based on the results of an exposure assessment. The following eye/face protection(s) are recommended:  
 Safety Glasses with side shields

**Skin/hand protection**

No chemical protective gloves are required.

**Respiratory protection**

An exposure assessment may be needed to decide if a respirator is required. If a respirator is needed, use respirators as part of a full respiratory protection program. Based on the results of the exposure assessment, select from the following respirator type(s) to reduce inhalation exposure:  
 Half facepiece or full facepiece air-purifying respirator suitable for particulates

For questions about suitability for a specific application, consult with your respirator manufacturer.

**SECTION 9: Physical and chemical properties**

**9.1. Information on basic physical and chemical properties**

**General Physical Form:** Solid  
**Specific Physical Form:** Granule

3M Gold Catalyst AUC-16-1 05/12/14

|  |   |
|--|---|
| <b>Odor, Color, Grade:</b>                     | Odorless, grey, granular.                             |
| <b>Odor threshold</b>                          | <i>No Data Available</i>                              |
| <b>pH</b>                                      | <i>Not Applicable</i>                                 |
| <b>Melting point</b>                           | <i>Not Applicable</i>                                 |
| <b>Boiling Point</b>                           | <i>Not Applicable</i>                                 |
| <b>Flash Point</b>                             | No flash point  |
| <b>Evaporation rate</b>                        | <i>Not Applicable</i>                                 |
| <b>Flammability (solid, gas)</b>               | Not Classified  |
| <b>Flammable Limits(LEL)</b>                   | <i>Not Applicable</i>                                 |
| <b>Flammable Limits(UEL)</b>                   | <i>Not Applicable</i>                                 |
| <b>Vapor Pressure</b>                          | <i>Not Applicable</i>                                 |
| <br>   |   |
| <b>Vapor Density</b>                           | <i>Not Applicable</i>                                 |
| <br>   |   |
| <b>Density</b>                                 | 0.42 - 0.48 g/cm3 [ <i>Details: packing density</i> ] |
| <b>Specific Gravity</b>                        | 1.8 - 2.1 [ <i>Ref Std: WATER=1</i> ]                 |
| <br>   |   |
| <b>Solubility in Water</b>                     | Nil   |
| <b>Solubility- non-water</b>                   | <i>No Data Available</i>                              |
| <br>   |   |
| <b>Partition coefficient: n-octanol/ water</b> | <i>Not Applicable</i>                                 |
| <b>Autoignition temperature</b>                | >=250 °C  |
| <b>Decomposition temperature</b>               | <i>No Data Available</i>                              |
| <b>Viscosity</b>                               | <i>Not Applicable</i>                                 |
| <b>VOC Less H2O &amp; Exempt Solvents</b>      | <i>Not Applicable</i>                                 |

## SECTION 10: Stability and reactivity

### 10.1. Reactivity

This material may be reactive with certain agents under certain conditions - see the remaining headings in this section.

### 10.2. Chemical stability

Stable.

### 10.3. Possibility of hazardous reactions

Hazardous polymerization will not occur.

### 10.4. Conditions to avoid

None known.

### 10.5. Incompatible materials

Strong oxidizing agents

### 10.6. Hazardous decomposition products

Substance  
None known.

Condition

Refer to section 5.2 for hazardous decomposition products during combustion.

## SECTION 11: Toxicological information

The information below may not be consistent with the material classification in Section 2 if specific ingredient

|                                    |
|------------------------------------|
| 3M Gold Catalyst AUC-16-1 05/12/14 |
|------------------------------------|

classifications are mandated by a competent authority. In addition, toxicological data on ingredients may not be reflected in the material classification and/or the signs and symptoms of exposure, because an ingredient may be present below the threshold for labeling, an ingredient may not be available for exposure, or the data may not be relevant to the material as a whole.

**11.1. Information on Toxicological effects**

**Signs and Symptoms of Exposure**

Based on test data and/or information on the components, this material may produce the following health effects:

**Inhalation:**

Respiratory Tract Irritation: Signs/symptoms may include cough, sneezing, nasal discharge, headache, hoarseness, and nose and throat pain.

**Skin Contact:**

Mechanical Skin irritation: Signs/symptoms may include abrasion, redness, pain, and itching.

**Eye Contact:**

Mechanical eye irritation: Signs/symptoms may include pain, redness, tearing and corneal abrasion.

**Ingestion:**

Gastrointestinal Irritation: Signs/symptoms may include abdominal pain, stomach upset, nausea, vomiting and diarrhea.

**Carcinogenicity:**

Contains a chemical or chemicals which can cause cancer.

| Ingredient               | C.A.S. No. | Class Description             | Regulation                                  |
|--------------------------|------------|-------------------------------|---|
| ANATASE TITANIUM DIOXIDE | 1317-70-0  | Grp. 2B: Possible human carc. | International Agency for Research on Cancer |

**Toxicological Data**

If a component is disclosed in section 3 but does not appear in a table below, either no data are available for that endpoint or the data are not sufficient for classification.

**Acute Toxicity**

| Name                     | Route                          | Species | Value   |
|--------------------------|--------------------------------|---------|---|
| Overall product          | Ingestion                      |         | No data available; calculated ATE > 5,000 mg/kg |
| ANATASE TITANIUM DIOXIDE | Dermal                         | Rabbit  | LD50 > 10,000 mg/kg                             |
| ANATASE TITANIUM DIOXIDE | Inhalation-Dust/Mist (4 hours) | Rat     | LC50 > 6.82 mg/l                                |
| ANATASE TITANIUM DIOXIDE | Ingestion                      | Rat     | LD50 > 10,000 mg/kg                             |

ATE = acute toxicity estimate

**Skin Corrosion/Irritation**

| Name                     | Species | Value                     |
|--------------------------|---------|---------------------------|
| ANATASE TITANIUM DIOXIDE | Rabbit  | No significant irritation |

**Serious Eye Damage/Irritation**

| Name                     | Species | Value                     |
|--------------------------|---------|---------------------------|
| ANATASE TITANIUM DIOXIDE | Rabbit  | No significant irritation |

**Skin Sensitization**

| Name                     | Species          | Value           |
|--------------------------|------------------|-----------------|
| ANATASE TITANIUM DIOXIDE | Human and animal | Not sensitizing |

3M Gold Catalyst AUC-16-1 05/12/14

**Respiratory Sensitization**

| Name | Species | Value |
|------|---------|-------|
|      |         |       |

**Germ Cell Mutagenicity**

| Name                     | Route    | Value         |
|--------------------------|----------|---------------|
| ANATASE TITANIUM DIOXIDE | In Vitro | Not mutagenic |
| ANATASE TITANIUM DIOXIDE | In vivo  | Not mutagenic |

**Carcinogenicity**

| Name                     | Route      | Species                 | Value            |
|--------------------------|------------|-------------------------|------------------|
| ANATASE TITANIUM DIOXIDE | Ingestion  | Multiple animal species | Not carcinogenic |
| ANATASE TITANIUM DIOXIDE | Inhalation | Rat                     | Carcinogenic     |

**Reproductive Toxicity**

**Reproductive and/or Developmental Effects**

| Name | Route | Value | Species | Test Result | Exposure Duration |
|------|-------|-------|---------|-------------|-------------------|
|      |       |       |         |             |                   |

**Target Organ(s)**

**Specific Target Organ Toxicity - single exposure**

| Name | Route | Target Organ(s) | Value | Species | Test Result | Exposure Duration |
|------|-------|-----------------|-------|---------|-------------|-------------------|
|      |       |                 |       |         |             |                   |

**Specific Target Organ Toxicity - repeated exposure**

| Name                     | Route      | Target Organ(s)    | Value  | Species | Test Result         | Exposure Duration     |
|--------------------------|------------|--------------------|--|---------|---------------------|-----------------------|
| ANATASE TITANIUM DIOXIDE | Inhalation | respiratory system | Some positive data exist, but the data are not sufficient for classification | Rat     | LOAEL 0.010 mg/l    | 2 years               |
| ANATASE TITANIUM DIOXIDE | Inhalation | pulmonary fibrosis | All data are negative  | Human   | NOAEL Not available | occupational exposure |

**Aspiration Hazard**

| Name | Value |
|------|-------|
|      |       |

Please contact the address or phone number listed on the first page of the SDS for additional toxicological information on this material and/or its components.

**SECTION 12: Ecological information**

**Ecotoxicological information**

Please contact the address or phone number listed on the first page of the SDS for additional ecotoxicological information on this material and/or its components.

**Chemical fate information**

Please contact the address or phone number listed on the first page of the SDS for additional chemical fate information on this material and/or its components.

**SECTION 13: Disposal considerations**

3M Gold Catalyst AUC-16-1 05/12/14

### **13.1. Disposal methods**

Dispose of contents/ container in accordance with the local/regional/national/international regulations.

Incinerate in a permitted waste incineration facility. Proper destruction may require the use of additional fuel during incineration processes. As a disposal alternative, utilize an acceptable permitted waste disposal facility. Empty drums/barrels/containers used for transporting and handling hazardous chemicals (chemical substances/mixtures/preparations classified as Hazardous as per applicable regulations) shall be considered, stored, treated & disposed of as hazardous wastes unless otherwise defined by applicable waste regulations. Consult with the respective regulating authorities to determine the available treatment and disposal facilities.

**EPA Hazardous Waste Number (RCRA):** Not regulated

## **SECTION 14: Transport Information**

For Transport Information, please visit <http://3M.com/Transportinfo> or call 1-800-364-3577 or 651-737-6501.

## **SECTION 15: Regulatory information**

### **15.1. US Federal Regulations**

Contact 3M for more information.

#### **311/312 Hazard Categories:**

Fire Hazard - No Pressure Hazard - No Reactivity Hazard - No Immediate Hazard - No Delayed Hazard - Yes

### **15.2. State Regulations**

Contact 3M for more information.

### **15.3. Chemical Inventories**

The components of this material are in compliance with the provisions of Australia National Industrial Chemical Notification and Assessment Scheme (NICNAS). Certain restrictions may apply. Contact the selling division for additional information.

The components of this product are in compliance with the new substance notification requirements of CEPA.

The components of this material are in compliance with the China "Measures on Environmental Management of New Chemical Substance". Certain restrictions may apply. Contact the selling division for additional information.

The components of this material are in compliance with the provisions of the Korean Toxic Chemical Control Law. Certain restrictions may apply. Contact the selling division for additional information.

The components of this material are in compliance with the provisions of Philippines RA 6969 requirements. Certain restrictions may apply. Contact the selling division for additional information.

The components of this product are in compliance with the chemical notification requirements of TSCA.

Contact 3M for more information.

### **15.4. International Regulations**

Contact 3M for more information.

**This SDS has been prepared to meet the U.S. OSHA Hazard Communication Standard, 29 CFR 1910.1200.**



3M Gold Catalyst AUC-16-1 05/12/14

**SECTION 16: Other information**

**NFPA Hazard Classification**

**Health: 1 Flammability: 1 Instability: 0 Special Hazards: None**

National Fire Protection Association (NFPA) hazard ratings are designed for use by emergency response personnel to address the hazards that are presented by short-term, acute exposure to a material under conditions of fire, spill, or similar emergencies. Hazard ratings are primarily based on the inherent physical and toxic properties of the material but also include the toxic properties of combustion or decomposition products that are known to be generated in significant quantities.

|                        |           |                         |          |
|------------------------|-----------|-------------------------|----------|
| <b>Document Group:</b> | 26-4485-4 | <b>Version Number:</b>  | 3.00     |
| <b>Issue Date:</b>     | 05/12/14  | <b>Supersedes Date:</b> | 08/03/10 |

DISCLAIMER: The information in this Safety Data Sheet (SDS) is believed to be correct as of the date issued. 3M MAKES NO WARRANTIES, EXPRESSED OR IMPLIED, INCLUDING, BUT NOT LIMITED TO, ANY IMPLIED WARRANTY OF MERCHANTABILITY OR FITNESS FOR A PARTICULAR PURPOSE OR COURSE OF PERFORMANCE OR USAGE OF TRADE. User is responsible for determining whether the 3M product is fit for a particular purpose and suitable for user's method of use or application. Given the variety of factors that can affect the use and application of a 3M product, some of which are uniquely within the user's knowledge and control, it is essential that the user evaluate the 3M product to determine whether it is fit for a particular purpose and suitable for user's method of use or application.

3M provides information in electronic form as a service to its customers. Due to the remote possibility that electronic transfer may have resulted in errors, omissions or alterations in this information, 3M makes no representations as to its completeness or accuracy. In addition, information obtained from a database may not be as current as the information in the SDS available directly from 3M

**3M USA SDSs are available at [www.3M.com](http://www.3M.com)**