



# A50 Carbon Dioxide Detector

## User Manual



**CAUTION: PLEASE READ THE SAFETY INFORMATION ON PAGES 4 AND 22 BEFORE INSTALLING THIS PRODUCT.**

**UK Office**  
15 Ellerbeck Court,  
Stokesley Business Park,  
North Yorkshire, TS9 5PT, UK



**US Office**  
15121 Graham Street #B106,  
Huntington Beach, California,  
92649

**UK / Global**  
info@analoxgroup.com  
+44 (0)1642 711 400



**US Office**  
ussales@analox.biz  
(714) 891 4478  
Toll Free: (877) 723 3247



## List of Contents

<b>1.</b>	<b>Safety Notes</b> .....	<b>4</b>
<b>2.</b>	<b>Packaging Contents Check</b> .....	<b>4</b>
<b>3.</b>	<b>About the A50</b> .....	<b>5</b>
<b>4.</b>	<b>A50 Accessories</b> .....	<b>6</b>
<b>5.</b>	<b>Effects of carbon dioxide</b> .....	<b>7</b>
<b>6.</b>	<b>Installation</b> .....	<b>8</b>
6.1.	How to fit an A50.....	8
6.2.	Remote Alarm Repeaters.....	12
6.2.1.	To connect a "Hard Wired" Remote Alarm Repeater .....	12
6.2.2.	To connect a "Quick Connect" Remote Alarm Repeater.....	13
6.3.	Cleaning.....	13
<b>7.</b>	<b>Operation</b> .....	<b>14</b>
7.1.	Operation at Altitude .....	14
<b>8.</b>	<b>Alarm Indications</b> .....	<b>15</b>
8.1.	Standard Unit .....	15
8.2.	TWA (Time Weighted Average) .....	15
8.3.	Lamp and Alarm Test .....	15
8.3.1.	Summary of Status Indicator Lamps.....	16
<b>9.</b>	<b>Instrument Calibration &amp; Test</b> .....	<b>17</b>
9.1.	Zero calibration adjustment .....	17
9.2.	Alarm Test.....	19
9.3.	Adjusting the Alarm Setpoints .....	20
9.3.1.	Adjusting Alarm Setpoints.....	20
<b>10.</b>	<b>Menu Navigation Flow Chart</b> .....	<b>21</b>
<b>11.</b>	<b>Technical Specifications</b> .....	<b>22</b>
<b>12.</b>	<b>Disposal</b> .....	<b>23</b>
<b>13.</b>	<b>Product variants</b> .....	<b>24</b>
13.1.	Part Number Matrix .....	24
<b>14.</b>	<b>Warranty Information</b> .....	<b>25</b>
<b>15.</b>	<b>Declaration of Conformity</b> .....	<b>26</b>
<b>16.</b>	<b>UK Declaration of Conformity</b> .....	<b>27</b>

## **1. Safety Notes**

Every gas monitor installation should be risk assessed. The correct location of monitor(s) must consider the potential sources of gas leaks and the location of expected human occupation in the area. Where large areas must be monitored, it is often advised that no single monitor should cover a volume in excess of 80m<sup>3</sup>. The installation of more monitors should be considered where an area is complex in shape, filled with obstacles, has a lack ventilation or air circulation, or if there are dead zones where gas can collect.

- a) The A50 must be installed according to these instructions which should be read entirely before commencing installation.
- b) For your convenience the Remote Alarm Repeater cable is pre-wired to the A50 sensor unit.
- c) The system **MUST NOT** be switched on until all connections have been correctly made.
- d) We do not recommend you access the main unit. Potentially lethal voltages exist within the A50. It should only be opened by a Qualified Technician and must be isolated from the electrical supply before opening.
- e) A proof test should be carried out at least 30 minutes after installation or relocation of the unit, and then at least every 18 months.

## **2. Packaging Contents Check**

The following items are enclosed:

- a) A50 main unit with power lead and 8 metres of interconnecting cable for connection to the Remote Alarm Repeater
- b) A50 quick start guide or user manual
- c) Test certificate
- d) Wall plugs and screws for wall mounting
- e) Remote Alarm Repeater
- f) Warning label

### **3. About the A50**

The A50 is designed to detect the presence of carbon dioxide in ambient air for the protection of people in confined spaces. The A50 provides audible and visual indication of potentially dangerous levels of carbon dioxide in the air surrounding the instrument. The instrument uses an infrared detector system, together with state of the art technology. It is housed in an IP65 splash proof enclosure, and is designed to provide long, trouble free service, with minimum maintenance. The Remote Alarm Repeater mimics the status indicators on the A50 unit. It also provides a push-button which operates in the same manner as the Mode button on the A50.

If you have more than one entrance to your cellar or store room you may need more than one Remote Alarm Repeater. Up to three repeaters can be daisy chained (one repeater linked to another) covering up to three entrance doors.

Optional items fitted to, or supplied with the unit may include the following (as shown in the photographs on Page 6):

- a) Splash guard
- b) Extra Remote Alarm Repeaters
- c) Calibration gasses

**4. A50 Accessories**

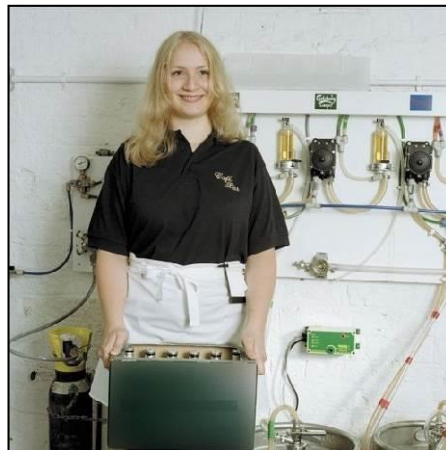

**NOTE:**

**\* -ITEMS A & B ARE CONSIDERED AS ACCESSORIES FOR SAFETY OPERATION OF THE EQUIPMENT, ONLY ANALOX SUPPLIED ACCESSORIES TO BE USED.**

**5. Effects of carbon dioxide**

1.000 ppm (0,1%)
5.000 ppm (0,5%)
10.000 ppm (1%)
15.000 ppm (1,5%)
20.000 ppm (2%)
30.000 ppm (3 %)
40.000- 50.000 ppm (4-5%)
50.000- 100.000 ppm (5-10%)
100.000- 1.000.000 ppm (10-100 %)



For a more detailed outline of the dangers of CO<sub>2</sub>, please visit our website [www.analoxgroup.com](http://www.analoxgroup.com)

## 6. Installation

### 6.1. How to fit an A50



**CAUTION:** CARBON DIOXIDE GAS (CO<sub>2</sub>) IS HEAVIER THAN AIR AND SHOULD BE MONITORED FROM A LOW HEIGHT. YOU SHOULD THEREFORE INSTALL THE CO<sub>2</sub> SENSOR AT A HEIGHT OF 12–18" (305–457MM) ABOVE THE FLOOR LEVEL.



**NOTE:** FOR OPTIMAL PERFORMANCE, IF THERE IS A LARGE VARIANCE BETWEEN WHERE UNITS ARE STORED AND WHERE THEY ARE INSTALLED, IT IS RECOMMENDED THAT UP TO 2 HOURS IS ALLOWED AFTER INSTALLATION BEFORE APPLYING POWER. THIS IS TO ALLOW FOR TEMPERATURE STABILIZATION IN THE UNIT WHICH IS IMPORTANT FOR DEVICE ACCURACY.

- 1] The Remote Alarm Repeater should be located at eye level and attached to the outside or immediately inside the access door.

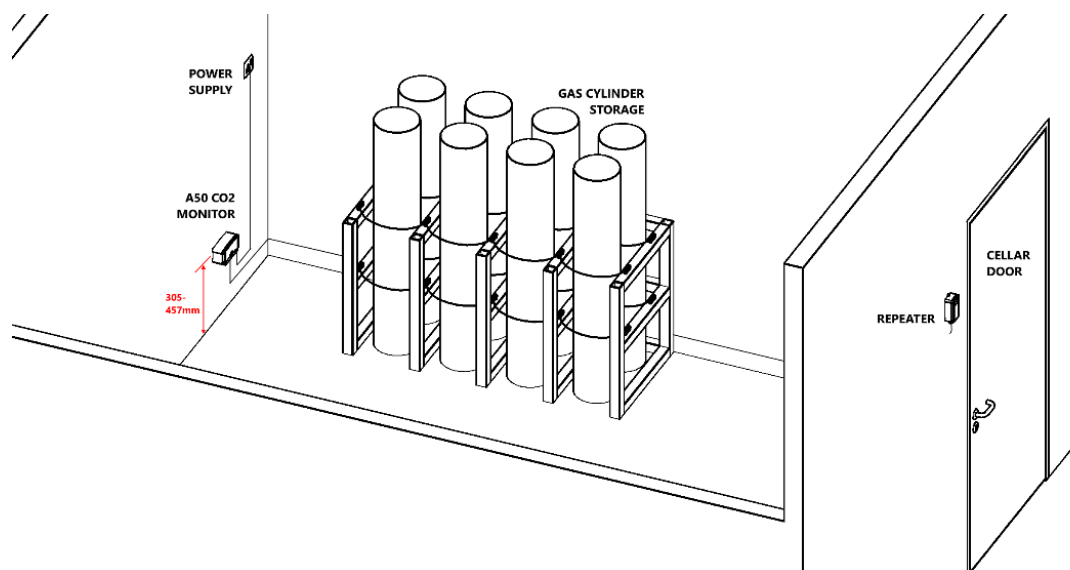



- 2] Attach the main unit to the wall 305-457mm from the floor as close to the valves and manifolds as possible.



- 3] A drilling template is included with this booklet.



- 4] The A50 should be mounted onto a wall using the mounting lugs on the unit. Wall plugs and screws are provided for this purpose. It is not necessary to dismantle the A50 main unit in any way prior to installation.

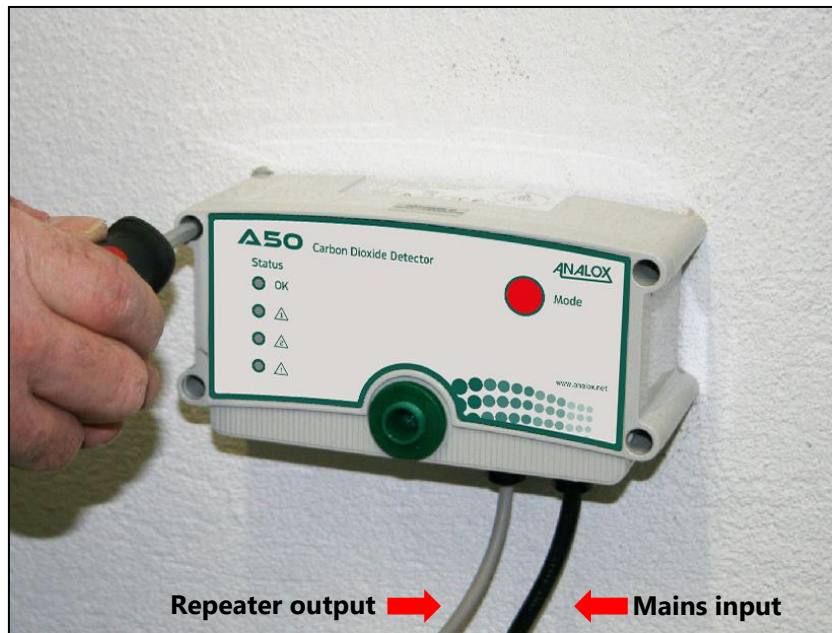

- 5] An 8 metre 8 core cable is pre-wired to the A50. Run the Remote Alarm Repeater cable to the outlet door, safely securing the cable with cable clips then wire up to the Alarm Repeater.



- 6] If the power supply for the A50 is not positioned so that it is close to the equipment and in easy reach of the operator, a local means of double pole isolation must be provided. Isolation can be achieved either by means of a non-locking plug or a double pole switch of suitable rating.
- 7] A label must be placed by the local disconnection point for the A50 stating: "REMOVE PLUG TO DISCONNECT A50"



- 8] Alarm Repeater connection can be achieved as per section 6.2



**Repeater connections (Hard wired shown)**

	<b>NOTE:</b>	<b>FIT THE SUPPLIED WARNING SIGN NEXT TO THE REPEATER</b>
--	--------------	---

**6.2. Remote Alarm Repeaters**









**6.2.1. To connect a “Hard Wired” Remote Alarm Repeater**

- 1] Disconnect the power supply from the A50.
- 2] Open the Remote Alarm Repeater unit by removing the 4 screws in the front of the case and carefully pulling the case apart. The connecting wires from the A50 pass through one of the cable glands on the Remote Alarm Repeater.

3] Terminate the wires in accordance with **Table 1**:

4] Replace the lid of the Remote Alarm Repeater, insert and tighten the 4 screws, and mount it in the desired position using the supplied wall plugs and screws.

5] Restore power to the A50. Press the Mode button on the Remote Alarm Repeater once and ensure that the four indicators flash.

<b>REPEATER CABLE COLOURS</b>	
<b>Type 2 (Cat 5)</b>	<b>Repeater Term</b>
	<b>8</b>
	<b>7</b>
	<b>6</b>
	<b>5</b>
	<b>4</b>
	<b>3</b>
	<b>2</b>
	<b>1</b>

*Table 1 Repeater wiring*

**6.2.2. To connect a “Quick Connect” Remote Alarm Repeater**

- 1] Disconnect the power supply from the A50.
- 2] Insert the connector on the end of the wire into either socket on the bottom of the Remote Alarm Repeater.
- 3] Restore power to the A50. Press the Mode button on the Remote Alarm Repeater once and ensure that the four indicators flash.



**NOTE:**

**IN THE PRESENCE OF A GENUINE ALARM, THIS TEST FEATURE IS DISABLED.**

**6.3. Cleaning**



**CAUTION:**

**DO NOT ATTEMPT TO CLEAN THE A50 WITH HIGH PRESSURE EQUIPMENT OR DIRECT WATER SPRAY**

All parts of the A50 may be cleaned with a soft cloth, moistened with water.

## **7. Operation**

When mains power is first applied to the A50, it requires a period of approximately 40 seconds to stabilise. During this period, the OK and Fault status indicators will be turned on. The OK status indicator will flash briefly every few seconds, indicating normal operation and after the initial stabilising period has expired, the Fault status indicator will turn off. The A50 will then be in its normal operating condition. During normal operation, the OK status indicator will flash on and off, thus indicating that the system is operating correctly. The OK status indicator on any Remote Alarm Repeaters will also flash on and off.

### **7.1. Operation at Altitude**

The toxic effects of carbon dioxide are dependent on the partial pressure, or the quantity of gas molecules, not the percentage in the atmosphere; therefore at altitudes above 900 metres (3000 feet) alarms will operate below the factory calibration point. Please refer to the [A50 CO<sub>2</sub> Monitor – Use at high altitude](#) document for details of suitable alarm set points and calibration procedures at altitude.

## **8. Alarm Indications**

### **8.1. Standard Unit**

If the A50 detects a carbon dioxide concentration which exceeds the first alarm level, the red Alarm 1 status indicator will begin to flash and the Horn will sound.

If the measured concentration of carbon dioxide continues to rise above the second alarm level, then the Alarm 2 status indicator will also begin to flash and the pace of the Horn will increase. This condition will be repeated on any Remote Alarm Repeaters. The alarms are self-cancelling when the carbon dioxide level falls below the alarm limits.



**NOTE:**

**FOR LATCHED SYSTEMS, ALARMS WILL CONTINUE TO SOUND AFTER THE GAS CONCENTRATION HAS FALLEN BELOW THE ALARM SET POINT UNTIL THE MODE BUTTON IS PRESSED**

	<b>Alarm 1</b>
	<b>Alarm 2</b>

### **8.2. TWA (Time Weighted Average)**

The A50 continuously monitors for elevated carbon dioxide concentrations above ambient, but below the first alarm. If the average carbon dioxide concentration over an 8-hour period is in excess of 5000ppm, the A50 will indicate a TWA alarm by slowly flashing the OK and Alarm 1 status indicators.



**NOTE:**

**HIGHER CONCENTRATIONS WILL ACTIVATE THE TWA ALARM QUICKER.**

A TWA alarm will only clear when the average carbon dioxide concentration over an 8 hour period falls to below 5000ppm. The TWA alarm is self-cancelling when the average carbon dioxide level falls below the alarm limits.

### **8.3. Lamp and Alarm Test**

Momentarily pressing the Mode button on either the A50 or any Remote Alarm Repeater, in the absence of any alarm conditions, causes a lamp and alarm test to be performed. The status indicators will flash 4 times, together with the horn. This test should be carried out each time the area is entered or at the start of each shift.

**8.3.1. Summary of Status Indicator Lamps**

<b>OK LAMP (GREEN)</b>	<b>ALARM1 LAMP (RED)</b>	<b>ALARM2 LAMP (RED)</b>	<b>FAULT LAMP (YELLOW)</b>	<b>MEANING</b>
OFF	OFF	OFF	OFF	Instrument power is off, check power and fuses
ON/ BLIP OFF	OFF	OFF	ON	40 second warmup
ON/ BLIP OFF	OFF	OFF	OFF	Normal Operation
FLASHING	FLASHING	OFF	OFF	TWA alarm *
OFF	FLASHING AND SLOW BUZZER	OFF	OFF	CO2 Level is > AL1 *
OFF	FLASHING	FLASHING AND MED. BUZZER	OFF	CO2 Level is >AL2% *
ON	OFF	OFF	OFF	Built in test fail **
OFF	OFF	OFF	FLASHING AND SLOW BUZZER	Internal Fault**
OFF	OFF	OFF	FLASHING AND MED. BUZZER	Detector Fault**
OFF	OFF	OFF	FLASHING AND FAST BUZZER	I.R. Source Fault***



**NOTE: \*** IF THIS ALARM IS BELIEVED TO BE INCORRECT, CARRY OUT A ZERO CALIBRATION ADJUSTMENT.



**NOTE: \*\*** POWER CYCLE THE SYSTEM. IF FAULT DOES NOT CLEAR, CONTACT YOUR SERVICE PROVIDER.



**NOTE: \*\*\*** AN IR SOURCE FAULT WILL NECESSITATE RETURNING THE UNIT FOR REPAIR.



## 9. Instrument Calibration & Test

### 9.1. Zero calibration adjustment



**NOTE: THIS PROCEDURE INVOLVES THE USE OF ZERO GAS. ZERO GAS MUST HAVE NO CARBON DIOXIDE (PURE NITROGEN IS SUITABLE).**



**NOTE: THE HORN WILL SOUND ON EACH PRESS OF THE MODE BUTTON**

- 1] Whilst the A50 is switched on, press the Mode button three times.
- 2] If this is done successfully, the instrument will enter technician mode. This is signified by the OK status indicator, which instead of flashing off for a brief period every few seconds will now flash on for a brief period every few seconds. If the instrument is left in this mode, it will return to normal operation after a short period. If technician mode is inadvertently selected, press the Mode button once to return to normal operation mode.
- 3] From technician mode, press the Mode button four times. If this is done successfully, the instrument will show both the Alarm 1 and Alarm 2 status indicators, indicating that zero calibration adjustment mode has been selected. If this is done inadvertently, or if another mode is selected, to cancel and return to technician mode, press the Mode button once
- 4] Pass zero gas (Nitrogen) over the sensor for two minutes at a flow rate of between 0.2 and 1 litre per minute (LPM).
- 5] To proceed with the zero calibration adjustment, press the Mode button twice. (Each press must be within 1 second of the previous).
- 6] The instrument will then monitor the gas sample for a period of one minute. The horn will sound once on completion after which the OK status indicator will extinguish.
- 7] During the zero calibration adjustment, the Alarm 1 and Alarm 2 status indicators show whether the sensor signal is within acceptable bounds. When the signal is acceptable, neither indicator will be on. If either indicator remains on, ensure that:
  - a) The sensor is exposed to zero gas (Nitrogen).
  - b) The adaptor is held over the sensor properly.

- 8] On completion of the sample period accept the zero calibration adjustment by pressing the Mode button twice, or alternatively ignore the adjustment by pressing the Mode button once. This will return to the technician mode. The reading can only be accepted provided the Alarm 1 and Alarm 2 status indicators are extinguished.
- 9] To exit technician mode, press the Mode button once. The A50 then restarts by performing the normal power on sequence.



**NOTE:**

**IF THE ZERO CALIBRATION ADJUSTMENT FAILED, THE PROCEDURE SHOULD BE PERFORMED AGAIN, AND IF STILL FAULTY, CONTACT YOUR SUPPLIER.**

## **9.2. Alarm Test**

The extent of the test depends on your requirements. To correctly verify operation of each alarm point the following tests are required:

- a) Check that at a selected tolerance below the alarm threshold, the alarm is not annunciated (e.g. at 1.3% CO<sub>2</sub> for a 1.5% CO<sub>2</sub> alarm)
- b) Check that at a selected tolerance above the alarm threshold, the alarm is annunciated (e.g. at 1.7% CO<sub>2</sub> for a 1.5% CO<sub>2</sub> alarm)

Some customers will be satisfied if only the second of these tests is performed, it is possible to judge by the time taken for an alarm to annunciate, whether the first test is likely to be satisfactory. Similarly, if only the Alarm 2 threshold is tested, the time taken to announce Alarm 1 can be used to judge the effectiveness of the Alarm 1 setting.

For the appropriate test method applicable to the use of the instrument:

- 1) Pass the appropriate test gas across the sensor.
- 2) Verify that the alarm operates as expected.

If the alarms fail to operate, adjust the Alarm Setpoints as detailed in Section 9.3

### 9.3. Adjusting the Alarm Setpoints

This procedure need only be performed when either the alarm setting is to be changed, or when the operation of the existing alarm is unsatisfactory.

#### 9.3.1. Adjusting Alarm Setpoints

This procedure is very similar for either the Alarm 1 or Alarm 2 setting.



**NOTE: PRIOR TO CARRYING CHANGING ANY ALARM LEVEL A ZERO CALIBRATION ADJUSTMENT MUST BE PERFORMED.**



**NOTE: THE HORN WILL SOUND ON EACH PRESS OF THE MODE BUTTON**

- 1] Whilst the A50 is switched on, press the Mode button three times
- 2] If this is done successfully, the instrument will enter technician mode. This is signified by the OK status indicator, which instead of flashing off for a brief period every few seconds will now flash on for a brief period every few seconds. If the instrument is left in this mode, it will return to normal operation after 1 minute. If technician mode is inadvertently selected, press the Mode button once to return to normal operation mode.
- 3] Pass the alarm calibration gas over the sensor for two minutes at a flow rate of between 0.2 and 1 litre per minute (LPM).
- 4] Dependant on the alarm to be adjusted.
  - a) For Alarm 1 adjustment press the Mode button two times
  - b) For Alarm 2 adjustment press the Mode button three times

The horn will sound on each press. If this is done successfully, the instrument will show the Fault status indicator and the appropriate Alarm status indicator. If this is done inadvertently, or if another mode is selected, press the Mode button once to return to technician mode and then repeat this selection.

- 5] To proceed with the alarm det operation, press the Mode button twice (Each press must be within 1 second of the previous).
- 6] The instrument will then monitor the gas sample for a period of one minute. The horn will sound once on completion after which the OK status indicator will extinguish.
- 7] On completion of the sample period the user may accept the new alarm by pressing the Mode button twice, or alternatively ignore the adjustment by pressing the Mode button once. This will return to the technician mode.

- 8] To exit from technician mode, press the Mode button once. The A50 then restarts by performing the normal power on sequence.

10. Menu Navigation Flow Chart

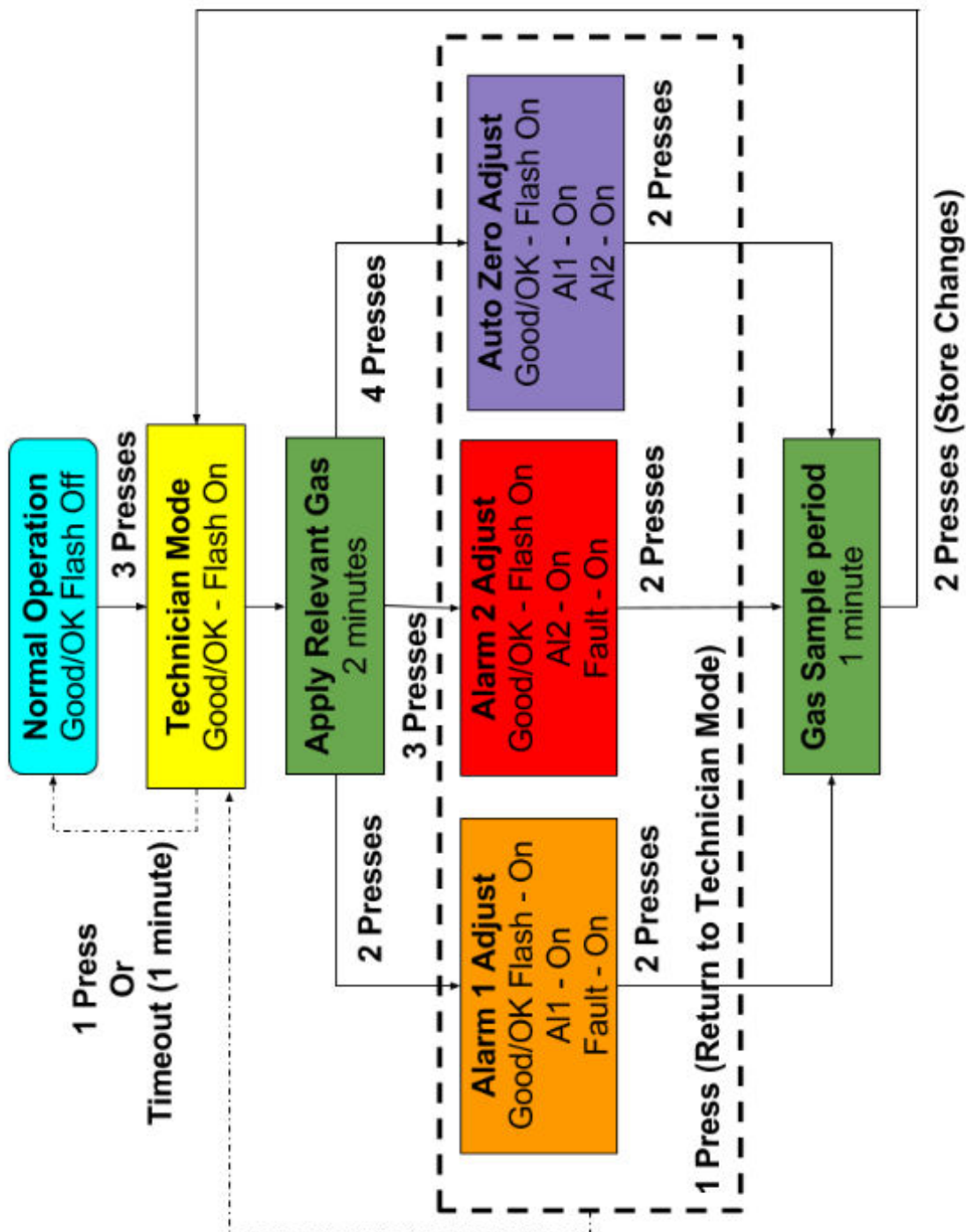

**11. Technical Specifications**

<b>Carbon dioxide</b>	Range 0.1-5%
<b>Response Time</b>	60 Seconds to T90
<b>Operating Temperature</b>	-5 to +40°C
<b>Temperature Effect</b>	<0.1%FS/°C
<b>Sensor Type - carbon dioxide</b>	Analox infrared detector
<b>Alarms</b>	2 x Alarm status indicators 1 x Fault status indicator 1 x OK status indicator Common Audible Alarm - Horn
<b>Power</b>	100 – 120 VAC, 50/60Hz, <5W or 100 – 250 VAC, 50/60Hz, <5W Mains voltage supply fluctuations not to exceed 10% of the nominal voltage
<b>Insulation</b>	 - Class II product Double insulation or reinforced insulation according to IEC 60417-5172 (2003-20)
<b>Overvoltage</b>	CAT II
<b>Pollution</b>	Pollution degree 2
<b>Humidity</b>	Maximum relative humidity 80% for temperatures up to 31°C decreasing linearly to 50% relative humidity at 40°C.
<b>Altitude</b>	<2000m
<b>General</b>	- Indoor use - Not for use in corrosive or explosive atmospheres** - Not approved for use in vehicles, ships or aircraft - The A50 conforms to DIN 6653-2:2015
<p>** - Item only relates to CSA requirements (North America only)</p> <p>If the equipment is used in a manner not specified by the manufacturer, the protection provided by the equipment may be impaired.</p> <p>Analox has a policy of continuous improvement, and we reserve the right to upgrade or change specifications without prior notice.</p>	

## **12. Disposal**



According to WEEE regulation this electronic product cannot be placed in household waste bins. Please check local regulations for information on the disposal of electronic products in your area.

### 13. Product variants

#### 13.1. Part Number Matrix

Instrument		Range		Alarms		Battery Backup*		Power Supply Plug	
A50	<b>A50</b>	0-5% CO <sub>2</sub>	<b>BC</b>	0.5/1.5%	<b>01</b>	N/A	<b>X</b>	Euro	<b>11</b>
A50M (Dual Repeater)	<b>A50M</b>			1.5/4.0%	<b>02</b>			Australia	<b>20</b>
				1.5/3.0%	<b>03</b>			UK	<b>55</b>
				1.5/3.0% (Latched)	<b>53</b>			US**	<b>56</b>
				TWA/1.5/3.0%	<b>60</b>				

Repeater		O <sub>2</sub> Sensor*		Outputs*		Display*		Language	
QC Strobe	<b>E</b>	N/A	<b>X</b>	N/A	<b>X</b>	N/A	<b>X</b>	English	<b>01</b>
HW Strobe	<b>G</b>							French	<b>03</b>
Hard Wired	<b>H</b>							German	<b>04</b>
2x Quick Connect	<b>K</b>							Dutch	<b>05</b>
Quick Connect	<b>Q</b>							Spanish	<b>06</b>
None	<b>X</b>							Custom 1	<b>11</b>
								Custom 2	<b>12</b>
								Custom 3	<b>18</b>
								Custom 4	<b>30</b>

\* - No longer applicable, for backwards compatibility only.

\*\* - CSA certified to IEC/CSA/UL 61010-3 3<sup>rd</sup> Ed.+AMD1



## **14. Warranty Information**

We provide the following Warranties for the A50:

A 5 year CO<sub>2</sub> Sensor Warranty.

A 2 year electronics Warranty.

In both cases the Warranty period runs from the date of our Invoice.

We warrant that the equipment will be free from defects in workmanship and materials.

The Warranty does not extend to and we will not be liable for defects caused by the effects of normal wear and tear, erosion, corrosion, fire, explosion, misuse, use in any context or application for which the equipment is not designed or recommended, or unauthorised modification.

The Warranty will be void and shall cease to be effective in the event that any alterations or repairs are made or attempted except in accordance with any specific previous written authorisation from us.

Following a valid Warranty claim in accordance with the above, the equipment, upon return to us, would be repaired or replaced without cost or charge but in our discretion we may elect instead to provide to you whichever is the lesser of the cost of replacement or a refund of net purchase price paid as per our Invoice on initial purchase from us. We shall have no liability for losses, damages, costs or delays whatsoever. We shall have no liability for any incidental or consequential losses or damages. All express or implied warranties as to satisfactory or merchantable quality, fitness for a particular or general purpose or otherwise are excluded and no such Warranties are made or provided, save as set out in this Clause 7.

In order to effectively notify a Warranty claim, the claim with all relevant information and documentation should be sent in writing to:

Analox Limited  
15 Ellerbeck Court  
Stokesley Business Park  
Stokesley  
North Yorkshire  
TS9 5PT

Or by e-mail to : [info@analoxgroup.com](mailto:info@analoxgroup.com)

We reserve the right to require from you proof of dispatch to us of the notification of Warranty claim by any of the above alternative means.

The equipment should not be sent to us without our prior written authority. All shipping and Insurance costs of returned equipment are to be borne by you and at your risk. All returned items must be properly and sufficiently packed.

15. Declaration of Conformity

Declaration of conformity

Declaration number: P0204-C501-01

Manufacturer's name: Analox Ltd

Manufacturer's address: 15 Ellerbeck Court
Stokesley Business Park
Stokesley
North Yorkshire
TS9 5PT

It is declared that the following product:

Product name: Analox 50 (A50)

Product code: A50xxxxxxxxxxxxxx

Conforms to all applicable requirements EN50270:2015 for Type 1 Equipment

of: FCC to class B levels according to title 47 of the Code of Federal
Regulations (CFR) part 15 (47CFR15):2008
UL 61010-1, 3rd edition (2012), AMD1: 2018
CAN/CSA C22.2 No. 61010-1-12, UPD1: 2015, UPD2: 2016, AMD1
DIN 6653-2:2015 (TUV)
AS 5034:2005

- Complies with the requirements of the EMC Directive 2014/30/EU
Complies with the requirements of the Low Voltage Directive 2014/35/EU, as amended
Complies with the requirements of the RoHS 2 Directive 2011/65/EU
Including amendments detailed in directive 2015/863 (RoHS 3)

FCC The above product is approved by FCC to class B levels according to title
47 of the Code of Federal Regulations (CFR) part 15 (47CFR15):2008

CE The above product is CE-marked and satisfies the relevant legislative
requirements of the European Economic Area (EEA)

CSA The above product is approved for use in the USA and Canada
Master Contract: 239512
Certificate: 70218489

TUV The above product is certified by TUV to comply with DIN 6653-2:2015
Report Number: 968/FSP 1630.01/19



Signed on behalf of: Analox Limited

Date: 11th June 2024

Signed: [Handwritten signature]

Name: Paul Branton

Position: Technical Director

**16. UK Declaration of Conformity**

**UK Declaration of Conformity**

**Declaration number:** P0204-C502-00

**Manufacturer's name:** Analox Limited

**Manufacturer's address:** 15 Ellerbeck Court  
Stokesley Business Park  
Stokesley  
North Yorkshire  
TS9 5PT

**It is declared that the following product:**

**Product name:** Analox 50 (A50)

**Product code:** A50xxxxxxxxxxxxx

**Conforms to all applicable requirements of:** EN50270:2015 for Type 1 Equipment  
UL 61010-1, 3rd edition (2012), AMD1:  
2018  
CAN/CSA C22.2 No. 61010-1-12, UPD1:  
2015, UPD2: 2016, AMD1

- Complies with the Electromagnetic Compatibility Regulations 2016
- The Electrical Equipment (Safety) Regulations 2016
- Complies with the requirements of UK RoHS 2012
- Complies with the requirements of WEEE Regulations 2013

The above product is UKCA-marked and satisfies the relevant legislative requirements of the UK



The above product is approved for use in the USA and Canada  
Master Contract: 239512  
Certificate: 70218489



**Signed on behalf of:** Analox Limited

**Date:** 14<sup>th</sup> June 2021

**Signed:**

**Name:** P Branton

**Position:** Technical Director